

BOC80 Series Celestial™ Collection

Installation Manual

BOC86, BOC82DT, BOC82



ORIGIN
ACOUSTICS

BANG & OLUFSEN

Table of Contents

Introduction	1
Specifications	2
Dual Tweeter	3
What's Included	4
Tools & Items	4
Wire Recommendation	4
Speaker Placement	5
About Speaker Wire	6
Installing the Wire	6
Wire Routing	7
Cutting the Hole	8
Installing the Bayonet Ring	8
Connecting the Wire	9
Installing the Speaker	9
Testing & Adjustments	11
Installing the Grille	11
Troubleshooting	12
Technical Assistance	13
Warranty	14
Return Process	15

Introduction

Thank you for purchasing the Celestial™ 8 In-Ceiling Speaker. Origin Acoustics and Bang & Olufsen take pride in providing you with high quality products. All of our speakers are designed to have excellent sound quality, longevity, and a simple installation process.

This instruction booklet covers the necessary information for a smooth installation, including: the tools you will need, step-by-step instructions for installation, troubleshooting tips for any errors that may occur, and all warranty information. If for any reason you experience problems or if you have installation questions please call us at (844) 674-4461. Hours of operation are 8:00am to 5:00pm (Pacific Time), Monday through Friday.

Specifications

Model	BOC86	BOC82DT/SUR	BOC82
Part Number	SCBOC80600	SCBOC2T802	SCBOC80200
Woofer Cone	Glass Fiber	IMG	IMG
Woofer Diameter	8" (203mm)	8" (203mm)	8" (203mm)
Mid-Range Dome	Glass Fiber	-	-
Mid-Range Diameter	4" (102mm)	-	-
Tweeter Dome	Silk DPSD	Silk DPSD	Silk DPSD
Tweeter Diameter	1" (25mm)	1" (25mm)	1" (25mm)
Frequency Response	34 Hz - 20 kHz	38 Hz - 20 kHz	38 Hz - 20 kHz
Impedance	6 ohm Minimum	6 ohm Minimum	6 ohm Minimum
Power RMS	50 Watts	50 Watts	50 Watts
Power Peak	150 Watts	150 Watts	150 Watts
Diameter	9 5/8" (244mm)	9 5/8" (244mm)	9 5/8" (244mm)
Grille Diameter	10" (254mm)	10" (254mm)	10" (254mm)
Cutout Diameter	8 3/4" (222mm)	8 3/4" (222mm)	8 3/4" (222mm)
Mounting Depth	5 5/8" (142mm)	4 5/16"(109mm)	4 1/8"(105mm)

Dual Tweeters

The Dual Tweeter models can be used for either one channel (surround) or two channels (stereo). A switch is located on the back of the speaker to select which mode to use. One of the inputs is labeled for surround. This is the input that should be used if you're only using one channel.

Surround (Dipole)

In this mode, one channel is fed into both tweeters to be distributed throughout the area. This way in a multiple-speaker setup, one speaker can be a dedicated left speaker and another a dedicated right.

Stereo (Dipole)

In this mode, two channels are fed into the speaker: one channel for each tweeter. This setup is ideal for small rooms such as walk-in closets and bathrooms, as well as oddly-shaped areas such as hallways. With both left and right channels in one speaker, only one speaker is needed in smaller rooms. In areas like hallways, both channels can be evenly distributed throughout the area with multiple speakers.

Warning

If you are using a dual tweeter speaker in stereo mode (i.e. there are two wires connected to the speaker: one for the left channel and one for the right), do not set the switch to surround mode. This could damage the amplifier.

What's Included

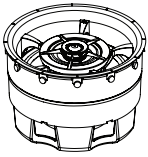

Speaker

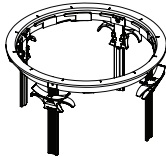

Bayonet Ring



Grille

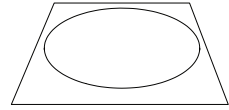

Template

Tools & Items

- Drywall Saw
- Speaker Wire
- Pencil
- Wire Stripper
- Measuring Tape
- Drill
- Drill Bit 1/8" (3mm)
- Stiff Wire
- Stud Finder
- Fish Tape

Wire Recommendation

The gauge of wire used can have an impact on the performance of your speakers. Use a multi-stranded wiring designed for amplifier to speaker connections. Which gauge to select depends on the length of wire to be used on any particular speaker. The longer your run is, the larger your wire size must be.

Wire Length	Wire Gauge
0 -100' (0 - 30m)	16 (1.5mm ²)
50 - 150' (15 - 45m)	14 (2.5mm ²)
Over 100' (30m)	12 (4mm ²)

Auxiliary Room (2 Speaker Placement)

Ideally, the two speakers should be placed an equal distance from the listener. If the room has a lower ceiling, the speakers can be closer together. Also, if the speaker placement is intended for standing (as opposed to sitting) listeners, the speakers can be closer together.

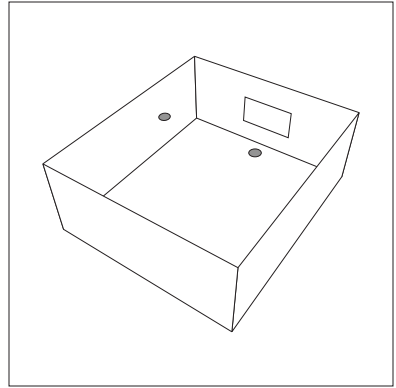

Home Theater (7 Speaker Placement)

The Left Rear (LR) and Right Rear (RR) speakers should be installed just behind the listener, one on either side. The Center Channel (CC) speaker should be placed above and slightly in front of the television, with the Left Front (LF) and Right Front (RF) speakers placed equidistant to either side.

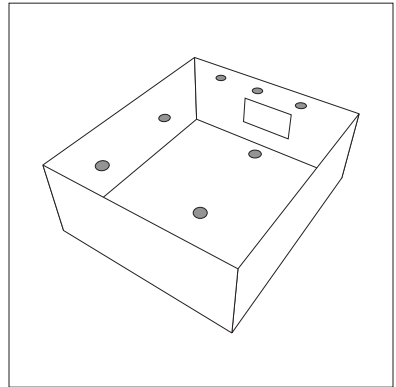

About Speaker Wire

Use a two conductor wire that allows you to identify one conductor from the other. This designation may be obvious or as subtle as a ridge on one conductor.

It's crucial that you keep track of which wire you use for positive (+) and negative (-). Typically if the wires are colored red and black, the red wire is used for positive and the black wire is used for negative, but sometimes other colors or patterns are used. You can choose whichever color of wire you want to be positive and negative as long as you remain consistent throughout the install.

On both your amplifier and your speaker the connectors will be identified as red for positive and black for negative. It is very important to look carefully at the speaker wires and be certain that the same wire that is attached to the positive connector in the amplifier is attached to the positive connector in the speaker.

1. Installing the Wire

Strip $\frac{1}{4}$ to $\frac{1}{2}$ inches (6 to 12 mm) of the insulation off both ends of the wire. To avoid stray strands, twist them at the end. Connect the wire to the amplifier, and make sure the wire connected to the left speaker output will be routed to the left speaker, right output to right speaker, etc.

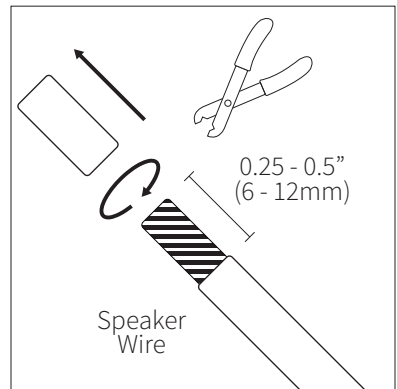

Wire Routing

Plan how you'll route the wire to the desired speaker location. There are several methods for routing the wire, and you may need to combine several of them.

Behind the Baseboard

The wire can be routed behind the baseboard by cutting a groove out of the back of the baseboard, or by buying special baseboard designed for concealing wires.

Through Walls

When running wires through a wall, be sure to avoid all obstacles such as AC wiring, pipes, and ducts.

Attic or Basement

When available, you can route the wire through an attic or crawlspace.

Under the Carpet

One option is to lift up the carpet and route "tape wire" under the carpet.

For New Construction

If these speakers are being installed in a new home during construction, the installation process will be a bit different (although much simpler). For these situations, it's recommended you purchase a bracket. Instructions on how to install the speakers are provided with the bracket, or can be found on our website. Visit www.originacoustics.com for more information.

2. Cutting the Hole

When you've decided on the locations for all of the speakers, use the template to trace a circle lightly in pencil where the hole should be. (Refer to the Specifications section for cutout sizes.) If you're unsure on whether there may be obstacles (such as pipes or wires) where you plan on installing the speaker, drill a 1/8 inch hole in the center of the circle, then put a bent coat hanger through the hole to feel around. Use a keyhole or drywall saw to cut the hole.

3. Installing the Bayonet Ring

Adjust the clips so that they're positioned at the top of the rail. If they're not already there you can do this by pushing the metal release tabs on the inside of the rail and pulling the clips to the top of the rails. Insert the bayonet ring into the hole in the ceiling by gently bending the rails inward. Reach inside the bayonet ring and push the clips down so that the bayonet ring is firmly in place, but not too tight. If the bayonet ring needs to be removed, reach inside and push the release tabs to reset the clips. The bayonet ring can now be taken out.

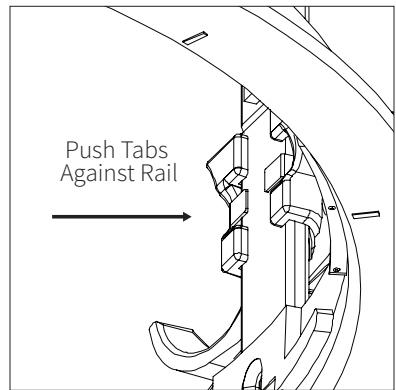
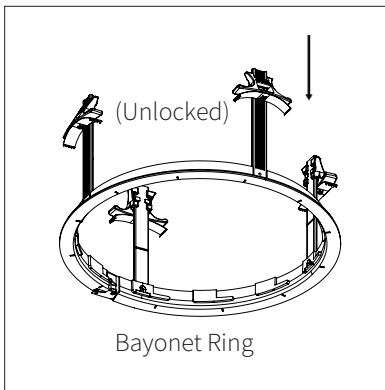

4. Connecting the Wire

Push down to open the connector. Insert the wires into the connectors, making sure that the positive wire is being attached to the red connection and the negative wire is being attached to the black connection. If the wires are switched, speaker performance will be drastically impacted.

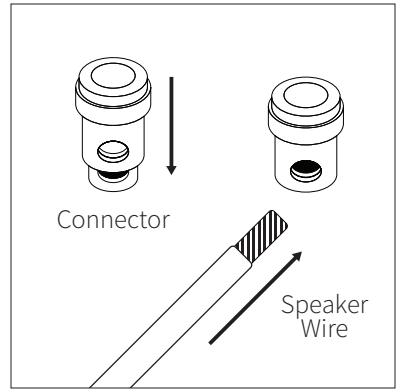

5. Installing the Speaker

STEP 1:

Fit the loudspeaker into the bayonet ring. Then twist the speaker about 15 degrees clockwise into place. When the loudspeaker is properly seated, the indicators on the ring and the speaker will line up.

***Important* The indicators must line up to ensure the speaker is properly seated.**

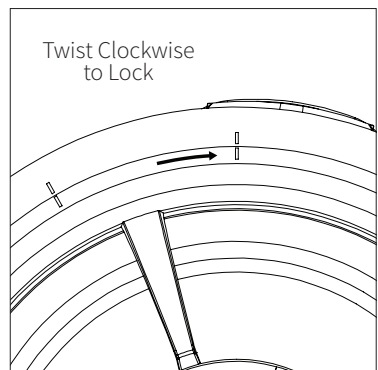
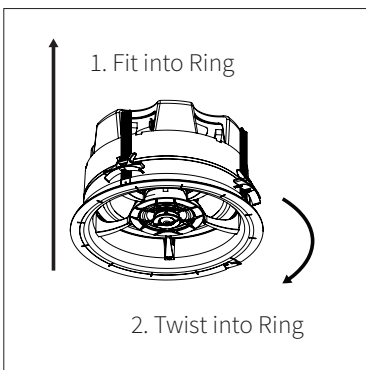

STEP 2:

The bayonet ring also features a metal lock to ensure the correct installation of the loudspeaker. Out of the box, the lock will be in its closed position. Open the lock tab to its unlocked position to remove the speaker from the ring. Once the speaker is installed, close the lock tab by pushing it back into place, flush with the perimeter of the bayonet ring.

***Important* Push the metal lock tab into its “LOCK” (closed) position after speaker is installed per step 1. This will secure the installation.** (See Figure A)

The loudspeaker must be properly seated, else the metal lock tab will not lock.

To uninstall the speaker, push the metal lock tab to its “UNLOCK” (open) position and twist the loudspeaker counterclockwise. (See Figure B)

Figure A

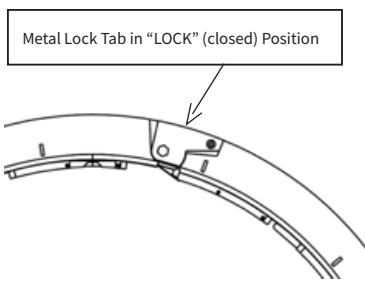
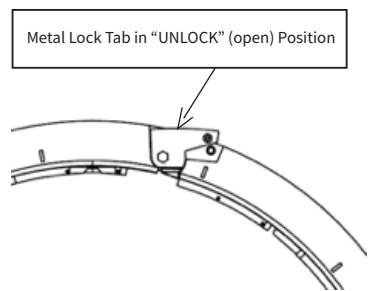
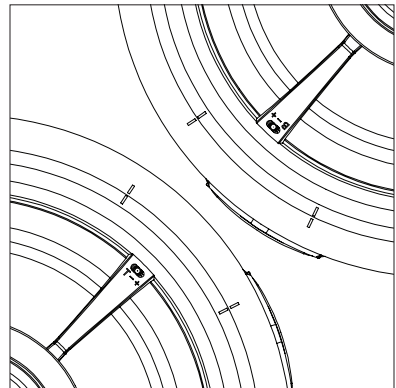
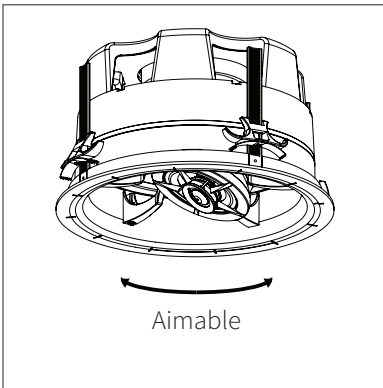

Figure B



6. Testing & Adjustments

The midrange (BOC86 only) and tweeter can be pivoted to direct the sound towards the listening area. Or for a more diffused surround sound experience, the rear speakers can be aimed towards the wall. To aim the tweeter, gently apply pressure to the rim with your thumbs to pivot the tweeter. To aim the midranges (BOC86 only), gently apply pressure to the rim and pivot it in the desired direction. Subject to which speaker is being used, there are two switches: one to adjust the treble, and one to adjust the bass. Depending on the area the speaker will be installed, bass and treble are affected by its surroundings. When the room has a lot of hard surfaces bass & treble are bounced and reflected through the room, if the room has softer surfaces the bass & treble are absorbed. Adjust for the desired acoustic balance for each room.



7. Installing the Grille

Fit the grille over the speaker. The grille uses magnets to be held in place.

Troubleshooting

If you have a problem, try isolating it first. For example, if you're playing a DVD and there is no sound, try replacing the DVD with an MP3 player to see if you get sound. If it does work, then the problem is with the television, DVD player, or the cables connecting them. If it doesn't work, the problem will be with the amplifier, speakers, or those cables.

Problem	Possible Cause
No Sound	The volume may be turned down or muted. Check the volume settings on both the amplifier and the source (television/computer/CD player/etc.)
No Sound	Make sure the proper source is selected on the amplifier or receiver.
No Sound	Check the cord connecting the amplifier with the source. The cord may be damaged or plugged into the wrong input or output.
No Sound	Check the wires connecting the amplifier with the speakers. Make sure they're connected properly and not damaged in any way.
Poor Sound Quality	If you hear something like static, or the sound is cutting in and out, check the audio cables. If the problem increases when a cable is being moved, then the cable is most likely faulty or not connected properly.
Poor Sound Quality	Today's audio systems may have several places to adjust the volume, for example your MP3 player may have a volume control, and your amplifier may also have one. Check to be certain that the volume isn't turned up past 80% on any device.
Poor Sound Quality	Try changing sources to be certain that the selection you've chosen is a good quality recording.

Technical Assistance

If you have any questions or concerns about installing or using this product, you can reach us through one of the following methods:

Phone: (844) 674-4461

Hours of operation: 8:00am - 5:00pm (Pacific Time), Mon - Fri

Email: techsupport@originacoustics.com

If you are having technical trouble, please include the model number and briefly explain what steps you took to resolve the problem in your email, or be prepared to answer these questions over the phone. If you are considering returning the product, it's required that you contact Origin Acoustics prior to any return attempts. This way we can determine if the issue can be resolved without returning the product, or if needed we can provide instructions and support for the return process.

Limited Lifetime Warranty

Origin Acoustics warrants to the original retail purchaser only that this Origin Acoustics product will be free from defects in materials and workmanship, provided the speaker was purchased from an Origin Acoustics authorized dealer.

If the product is determined to be defective, it will be repaired or replaced at Origin Acoustics' discretion. If the product must be replaced yet it is no longer manufactured, it will be replaced with a model of equal to or greater value that is the most similar to the original. If this is the case, installing the replacement model may require mounting modifications; Origin Acoustics will not be responsible for any such related costs.

Requirements & Warranty Coverage

This warranty may not be valid if the product was purchased through an unauthorized dealer. This warranty only applies to the individual that made the original purchase, and it cannot be applied to other purchases. The purchaser must be prepared to provide proof of purchase (receipt). This warranty will not be valid if the identifying number or serial number has been removed, defaced, or altered.

Not Covered by Warranty

- Accidental damage
- Damage caused by abuse or misuse
- Damage caused by attempted repairs/modifications by anyone other than Origin Acoustics or an authorized dealer
- Damage caused by improper installation
- Normal wear, maintenance, and environmental issues
- Damage caused by voltage inputs in excess of the rated maximum of the unit
- Damage inflicted during the return shipment

Return Process

Before making any return attempts, it is required that you first contact Origin Acoustics. Return product to Origin Acoustics or your dealer, either in person or by mail. It's preferable if the product is returned in the original packaging. If this isn't possible, the customer is responsible for insuring the shipment for the full value of the product.

This warranty is in lieu of all other expressed or implied warranties. Some states do not allow limitations on implied warranties, so this may not apply depending on the customer's location. (For more information, see Magnuson-Moss Warranty Act.)



www.originacoustics.com • 844-674-4461 • www.bang-olufsen.com

©2017 Origin Acoustics. All copyrighted, trademarked and patented elements mentioned herein are the sole property of Origin Acoustics. ©2017 Bang & Olufsen. All copyrighted, trademarked and patented elements mentioned herein are the sole property of Bang & Olufsen.