

artcoustic.com

Artcoustic^{AC}

SUBWOOFER SERIES

Owners manual

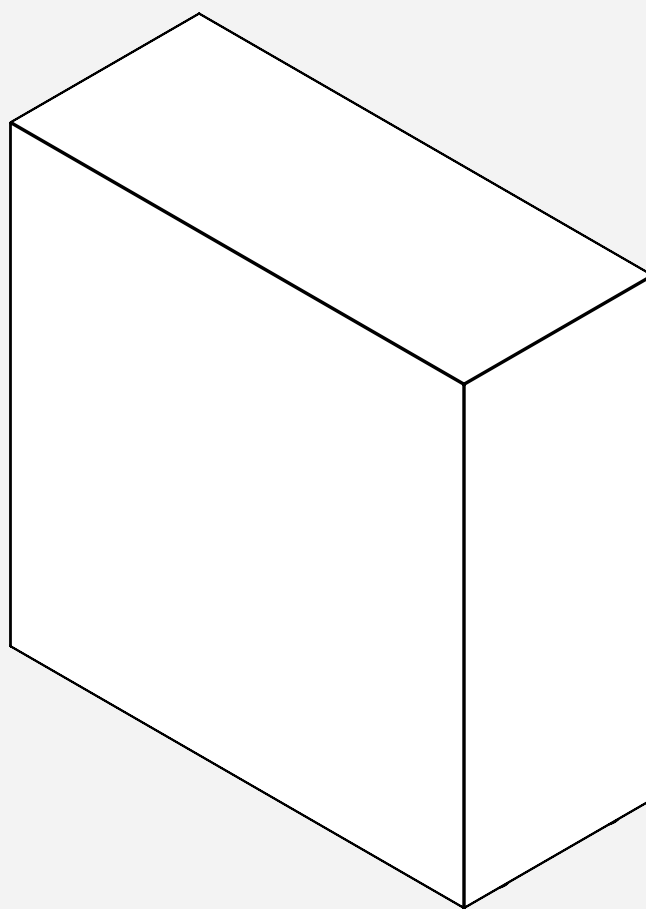

WELCOME TO THE WORLD OF ARTCOUSTIC

Congratulations with the purchase of your Artcoustic Subwoofer.

The Artcoustic Subwoofer Series has an efficient passive double-tuned bandpass design, producing a fast, dynamic bass response and exceptional musical authority, easily integrated into any small to large Artcoustic system.

The Artcoustic Subwoofer Series is designed with a low resonance frequency 4th order bandpass design, which ensures powerful and clean bass.

The Artcoustic Subwoofer Series fits well into a remarkably small projection screen installation space, featuring a single or up to four high-quality 10" bass units, mounted within a specially tuned, elegant and contemporary cabinet, offering discrete floor, cabinet or wall placement. This technology allows for superb output performance to be possible in a cabinet much smaller than would otherwise be required.

Nearly 20 years of subwoofer technology and acoustic evolution has merged into the most advanced and powerful subwoofer series ever produced by Artcoustic.

The Artcoustic Subwoofer Series delivers amazing bass, ideal for professional applications, such as recording and film studios, dedicated cinemas and fixed installations in general. Employing a single or up to four long-throw woofers, capable of reproducing low frequency signals accurately and effortlessly. For larger rooms, or where a higher SPL is required, use multiple units.

Thank you for purchasing an Artcoustic product.

All the best,
The Artcoustic Team

FEATURES

SUBWOOFER SERIES

The Artcoustic Subwoofer Series is ideal for use in high-end installations where sound quality is paramount, such as mid-field to full-space studio monitoring, for private cinema installations, and for commercial use in bars, restaurants and corporate presentation facilities, including commercial movie theatres.

LONG THROW BASS UNITS

HIGH LONG TERM POWER HANDLING

VERY LOW DISTORTION

VERY HIGH SPL

REMARKABLE DYNAMIC RANGE AND TRANSIENT RESPONSE

HEAT DISSIPATION, COMBINED WITH REDUCED DISTORTION MOTOR

FAST EASY AND SIMPLE INSTALLATION

SUITABLE FOR A WIDE RANGE OF APPLICATION

Dedicated cinemas, screening rooms and most commercial applications

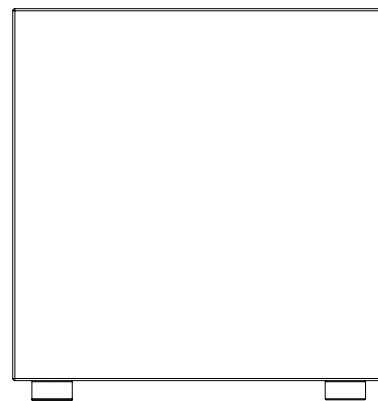

SUB3 front view

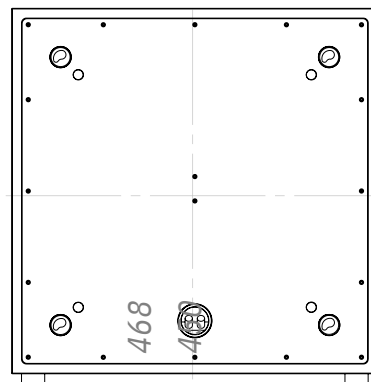

SUB3 rear view

SPECIFICATIONS

SUB Z SUBWOOFER

TRANSDUCER

LF 1 x 10 inch long throw cone

CONNECTION

Single amp'd Gold Plated Push Terminals

PERFORMANCE

Operating Range 35 Hz (-3dB) to 120 Hz

Nominal Beamwidth omni directional

Axial Sensitivity (half space SPL) LF 94 dB

Input Impedance Nominal Minimum 8 ohms

Maximum Power Handling 160 Watt

Calculated Axial Output Limit (half space SPL) Average Peak 110 dB

DESIGN

Cabinet: Black, White, RAL, NCS, Tikkurila, Gloss

Weight 10 kg

Dimensions H: 350 W: 350 D: 200 mm

Artcoustic Sub Z is the smallest subwoofer in our line up. This subwoofer delivers amazing bass, ideal for smaller installations, residential TV setup and smaller sized cinemas, commercial installations, such as bars, restaurants and cafés.

The Sub Z employs one 10 inch long-throw woofer, combined with the Artcoustic in-house designed 4th order bandpass technology, making this sub capable of reproducing low frequency signals accurately and effortlessly, with high power handling and extremely low distortion, right down to 35 Hz.

The Artcoustic Sub Z subwoofer is ideal for use in high-end installations where sound quality is paramount, for higher output, use multiple units.

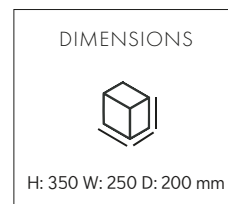
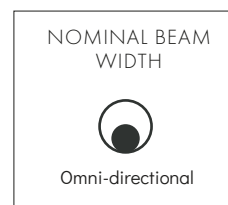
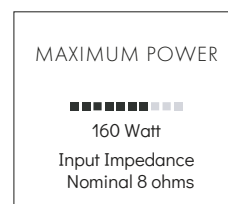
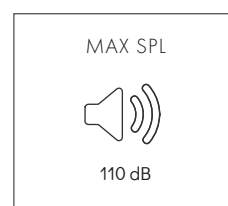
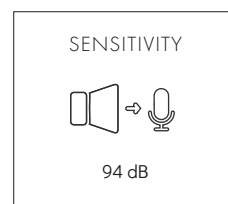
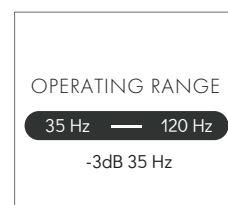

SPECIFICATIONS

SUB Z-IWS IN-WALL SUBWOOFER

TRANSDUCER

LF 1 x 10 inch long throw cones

CONNECTION

Single amped Gold Plated Push Terminals

PERFORMANCE

Operating Range 35 Hz (-3dB) to 120 Hz

Nominal Beamwidth omni directional

Axial Sensitivity (half space SPL) LF 94 dB

Input Impedance Nominal Minimum 8 ohms

Maximum Power Handling 160 Watt

Calculated Axial Output Limit (half space SPL) Average Peak 110 dB

DESIGN

Cabinet: Black, White, RAL, NCS, Tikkurila, Gloss

Weight 10 kg

Dimensions H: 440 W: 440 D: 163 mm

Artcoustic Sub Z-IWS is the slimmest subwoofer in our line up. This in-wall subwoofer delivers amazing bass, ideal for smaller installations; residential TV setups, smaller sized cinemas and commercial installations, such as bars, restaurants and cafés.

The Sub Z-IWS employs one 10 inch long-throw woofer, combined with the Artcoustic in-house designed 4th order bandpass technology, making this sub capable of reproducing low frequency signals accurately and effortlessly, with high power handling and extremely low distortion, right down to 35 Hz.

The Artcoustic Sub Z-IWS subwoofer is ideal for use in high-end installations where sound quality is paramount. For higher output, use multiple units.

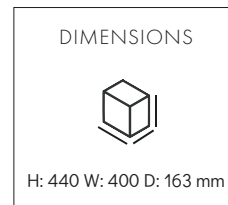
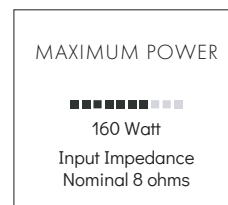
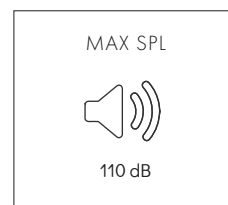
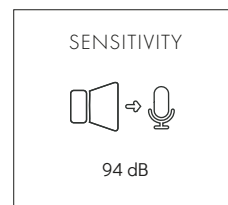
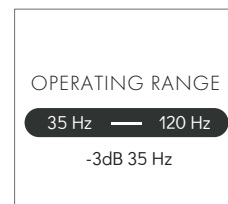

SPECIFICATIONS

SUB 1 SUBWOOFER

TRANSDUCER

LF 1 x 10 inch long throw cone

CONNECTION

Single amp'd Gold Plated Push Terminals

PERFORMANCE

Operating Range 30 Hz (-3dB) to 120 Hz

Nominal Beamwidth omni directional

Axial Sensitivity (half space SPL) LF 96 dB

Input Impedance Nominal Minimum 6 ohms

Maximum Power Handling 160 Watt

Calculated Axial Output Limit (half space SPL) Average Peak 115 dB

DESIGN

Cabinet: Black, White, RAL, NCS, Tikkurila, Gloss

Weight 12 kg

Dimensions H: 450 W: 450 D: 225 mm

Artcoustic Sub 1 delivers amazing bass ideal for professional applications, such as recording and film studios, dedicated cinemas and fixed installations in general.

The Sub 1 employs one 10 inch long-throw woofer, combined with the Artcoustic in-house designed 4th order bandpass technology, making this sub capable of reproducing low frequency signals accurately and effortlessly, with high power handling and extremely low distortion, right down to 30 Hz.

The Artcoustic Sub 1 subwoofer is ideal for use in high-end installations where sound quality is paramount.

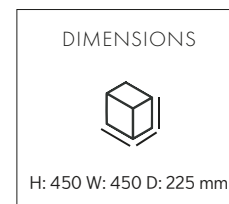
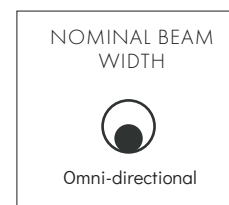
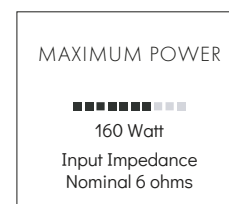
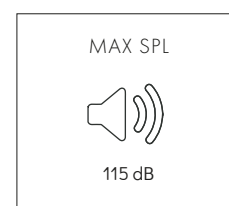
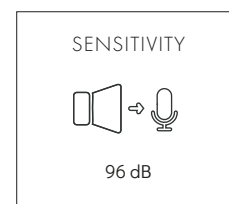
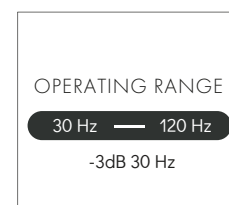

SPECIFICATIONS

SUB 2 SUBWOOFER

TRANSDUCER

LF 1 x 10 inch long throw cone

CONNECTION

Single amp'd Gold Plated Push Terminals

PERFORMANCE

Operating Range 27 Hz (-3dB) to 120 Hz

Nominal Beamwidth omni directional

Axial Sensitivity (half space SPL) LF 96 dB

Input Impedance Nominal Minimum 6 ohm

Maximum Power Handling 160 Watt

Calculated Axial Output Limit (half space SPL) Average Peak 116 dB

DESIGN

Cabinet: Black, White, RAL, NCS, Tikkurila, Gloss

Weight 14 kg

Dimensions H: 500 W: 500 D: 225 mm

For the ultimate in low-frequency performance, the Artcoustic Sub 2 subwoofer delivers awesome bass reproduction. This model changes the way subwoofers are perceived. Employing a single 10" long-throw woofer combined with the Artcoustic in-house designed 4th order bandpass technology, this subwoofer reproduces low frequency signals accurately and effortlessly, with high power handling and extremely low distortion, right down to 27Hz.

For its size, it is one of the most dynamic, powerful and controlled subwoofers on the market, making it ideal for professional applications, such as recording and film studios, smaller dedicated cinemas and fixed installations in general.

The Artcoustic Sub 2 subwoofer is ideal for use in high-end installations where sound quality is paramount, such as mid-field to full-space studio monitoring, for private cinema installations, and for commercial use in bars, restaurants and corporate presentation facilities. For high SPL requirements, use multiple units.

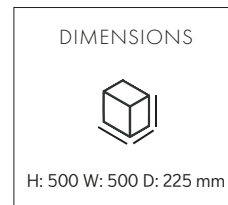
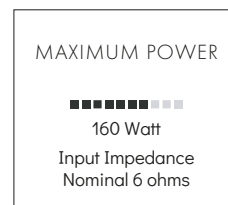
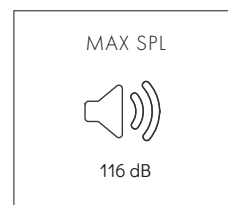
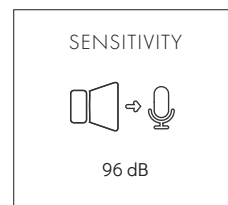
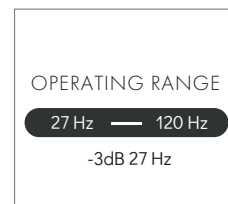

SPECIFICATIONS

SUB 3 SUBWOOFER

TRANSDUCER

LF 2 x 10 inch long throw cones

CONNECTION

Single amped Gold Plated Push Terminals

PERFORMANCE

Operating Range 20 Hz (-3dB) Hz to 120 Hz

Nominal Beamwidth omni directional

Axial Sensitivity (half space SPL) LF 96 dB

Input Impedance Nominal Minimum 14 ohms

Maximum Power Handling 320 Watt

Calculated Axial Output Limit (half space SPL) Average Peak 122 dB

DESIGN

Cabinet: Black, White, RAL, NCS, Gloss

Weight 33 kg

Dimensions H: 600 W: 600 D: 250 mm

For the ultimate in low-frequency performance, the Artcoustic Sub 3 subwoofer delivers awesome bass reproduction. For its size, it is one of the most dynamic, powerful and controlled subwoofers on the market, making it ideal for professional applications, such as recording and film studios, dedicated cinemas and fixed installations in general.

This model changes the way subwoofers are perceived. Employing two 10" long-throw woofers combined with our in-house 4th order bandpass technology, this subwoofer reproduces low frequency signals accurately and effortlessly, with high power handling and extremely low distortion, right down to 20Hz.

The Artcoustic Sub 3 subwoofer is ideal for use in high-end installations where sound quality is paramount, such as mid-field to full-space studio monitoring, for private cinema installations and for commercial use in bars, restaurants and corporate presentation facilities. For very high SPL requirements, use multiple units.

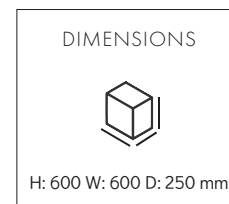
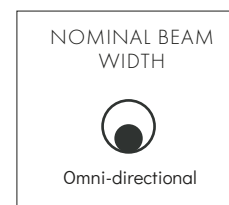
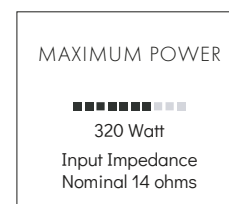
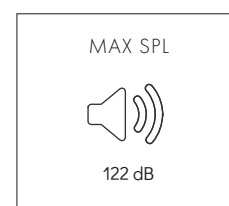
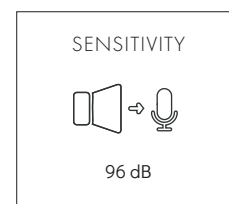
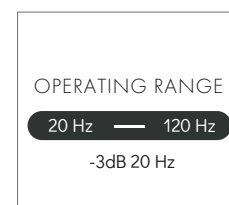

SPECIFICATIONS

SUB 4 SUBWOOFER

TRANSDUCER

LF 4 x 10 inch long throw cones

CONNECTION

Single amp'd Gold Plated Push Terminals

PERFORMANCE

Operating Range 15 Hz (-3dB) to 120 Hz

Nominal Beamwidth omni directional

Axial Sensitivity (half space SPL) LF 99 dB

Input Impedance Nominal 8 ohms

Maximum Power Handling 640 Watt

Calculated Axial Output Limit (half space SPL) Average Peak 128 dB

DESIGN

Cabinet: Black SL, White SL, RAL

Weight 61 kg

Dimensions H: 1000 W: 600 D: 250 mm

For the ultimate in low-frequency performance, the Artcoustic Sub 4 subwoofer is the largest and most powerful subwoofer in our lineup. The Sub 4 delivers unmatched bass reproduction and for its size, it is one of the most dynamic, powerful and controlled subwoofers on the market, making it ideal for professional applications, such as recording and film studios, dedicated cinemas and fixed installations in general.

This model changes the way subwoofers are perceived. Employing 4 10" long-throw woofers combined with our in-house 4th order bandpass technology, this subwoofer reproduces low frequency signals accurately and effortlessly, with high power handling and extremely low distortion, right down to 15Hz.

The Artcoustic Sub 4 subwoofer is ideal for use in high-end installations where sound quality is paramount, such as full-space studio monitoring, for private and commercial cinema installations and for commercial use in bars, clubs and corporate presentation facilities. For professional level SPL requirements, use multiple units.

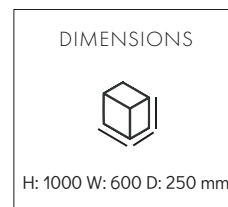
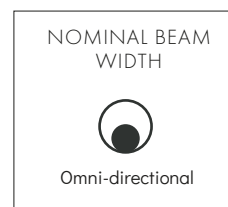
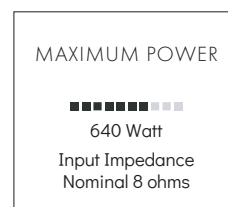
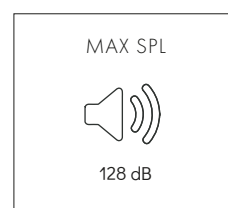
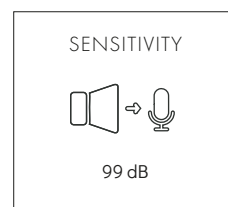
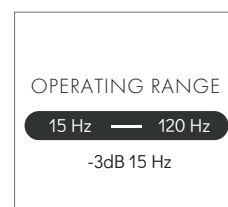

SCHEMATICS

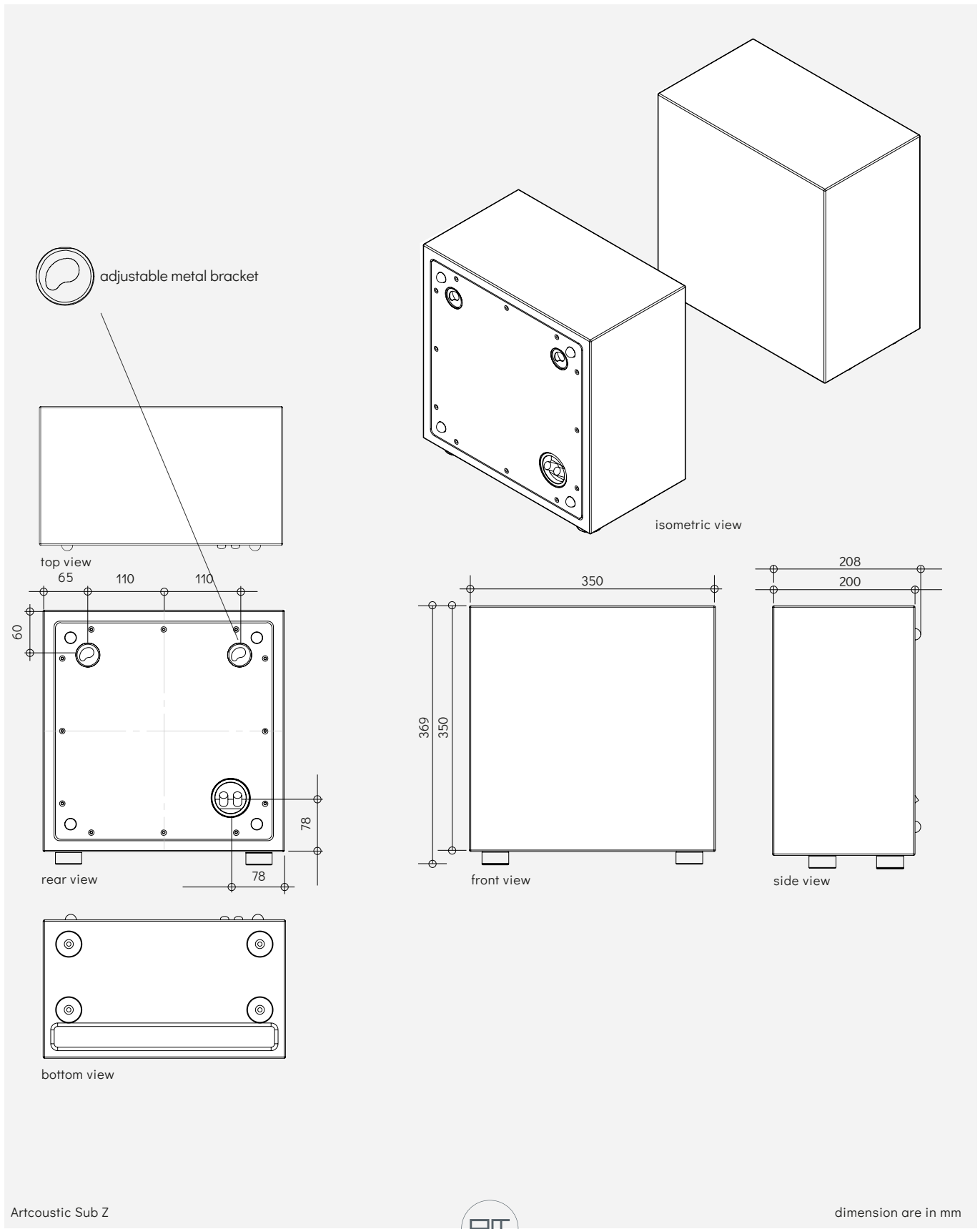

SCHEMATICS

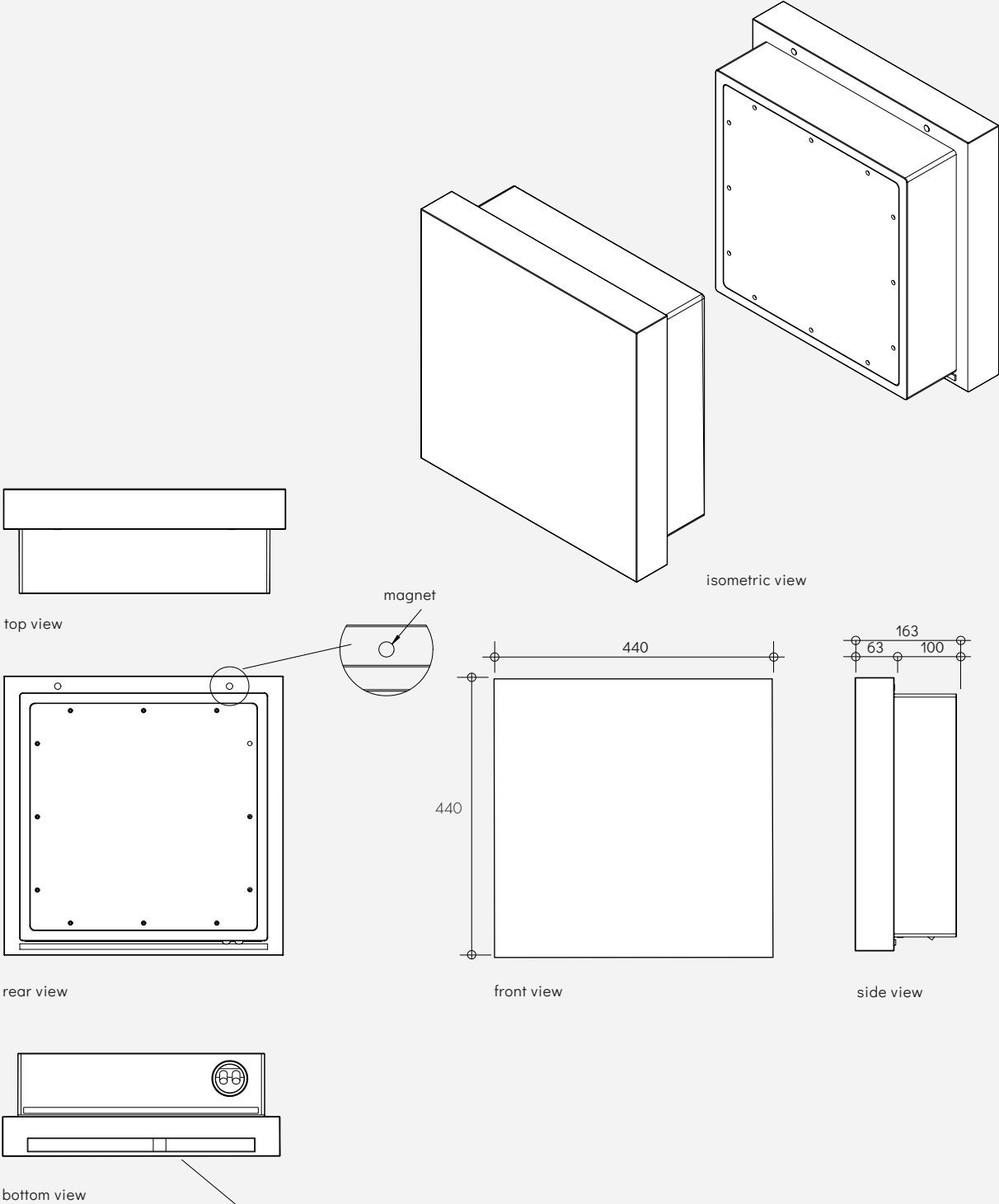

SCHEMATICS

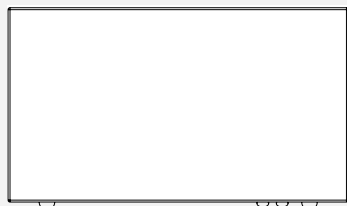

top view

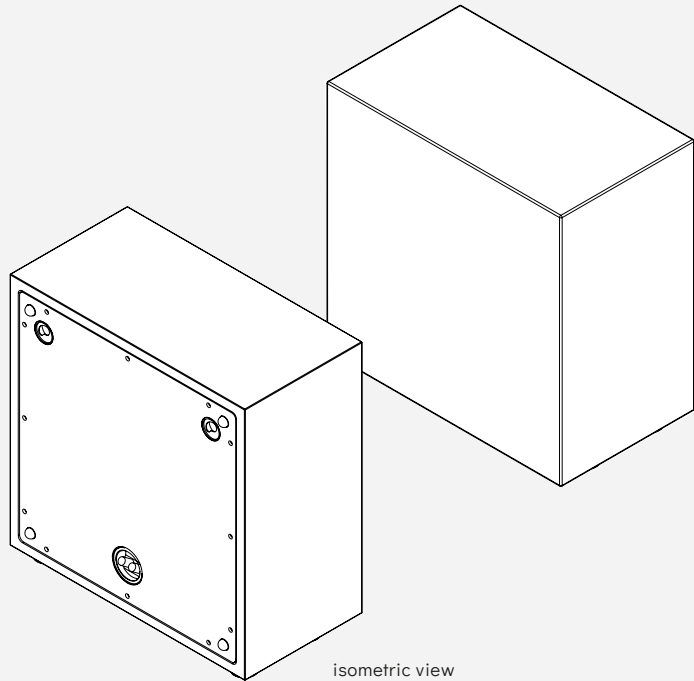

isometric view

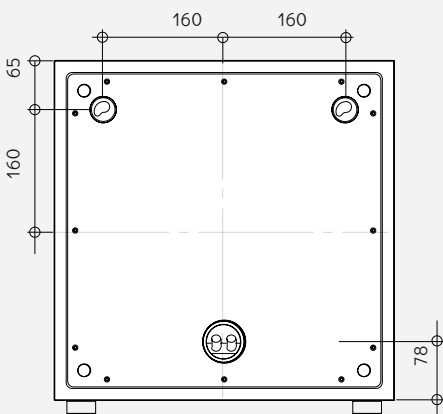

rear view

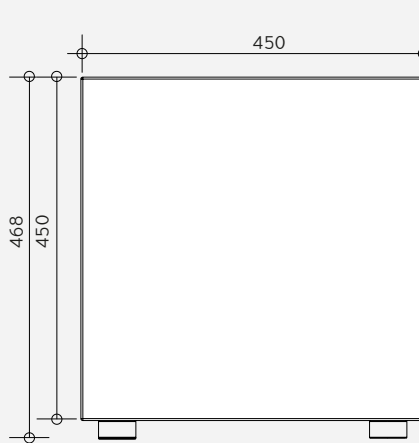

front view

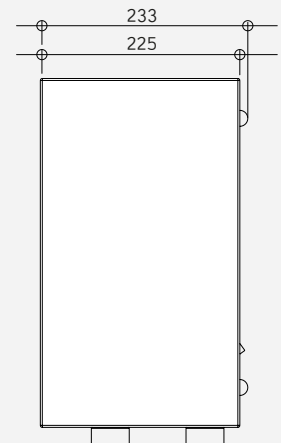

side view

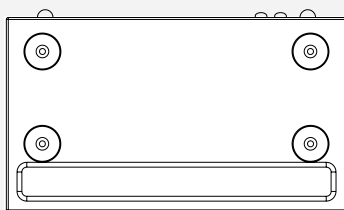

bottom view

SCHEMATICS

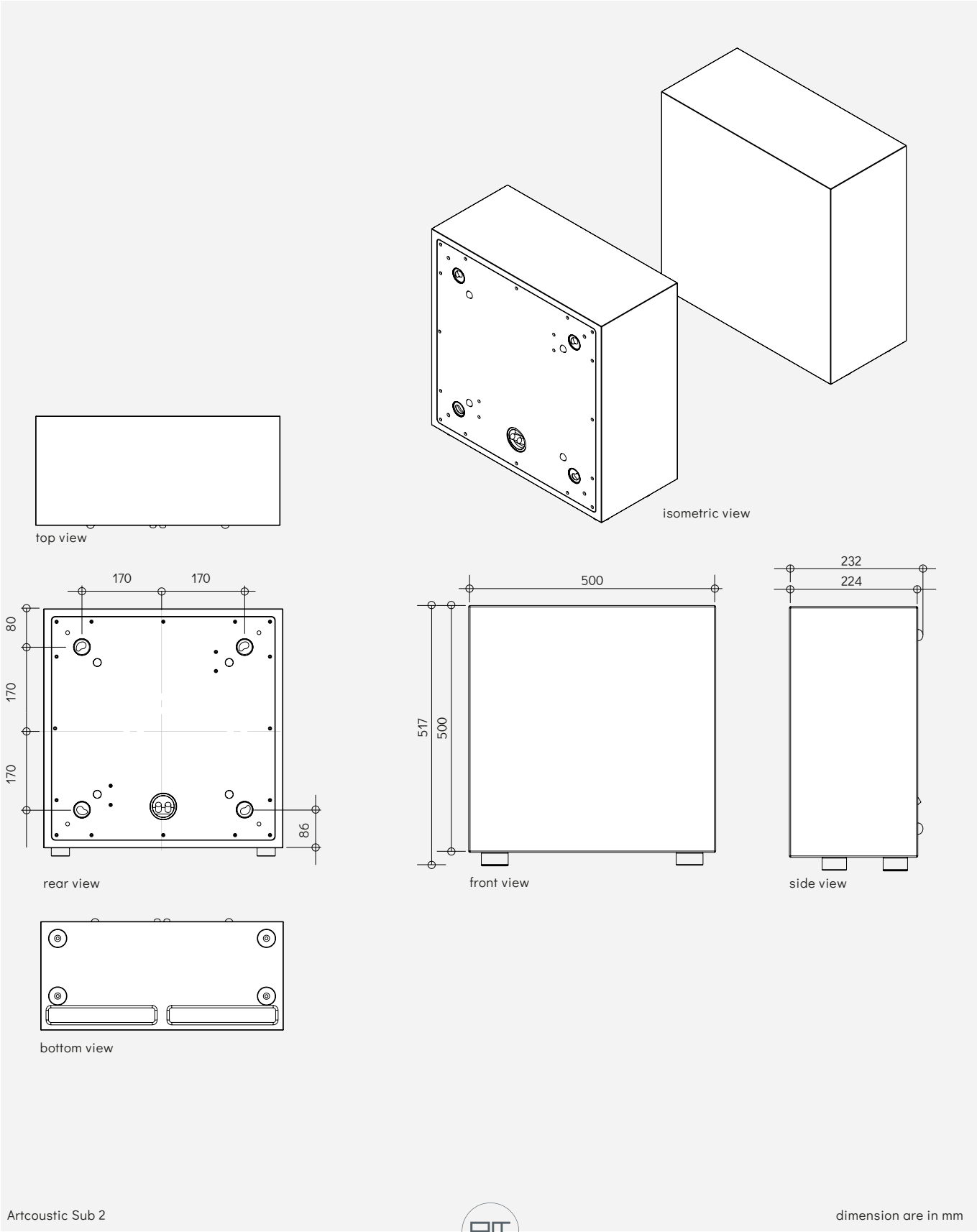

SCHEMATICS

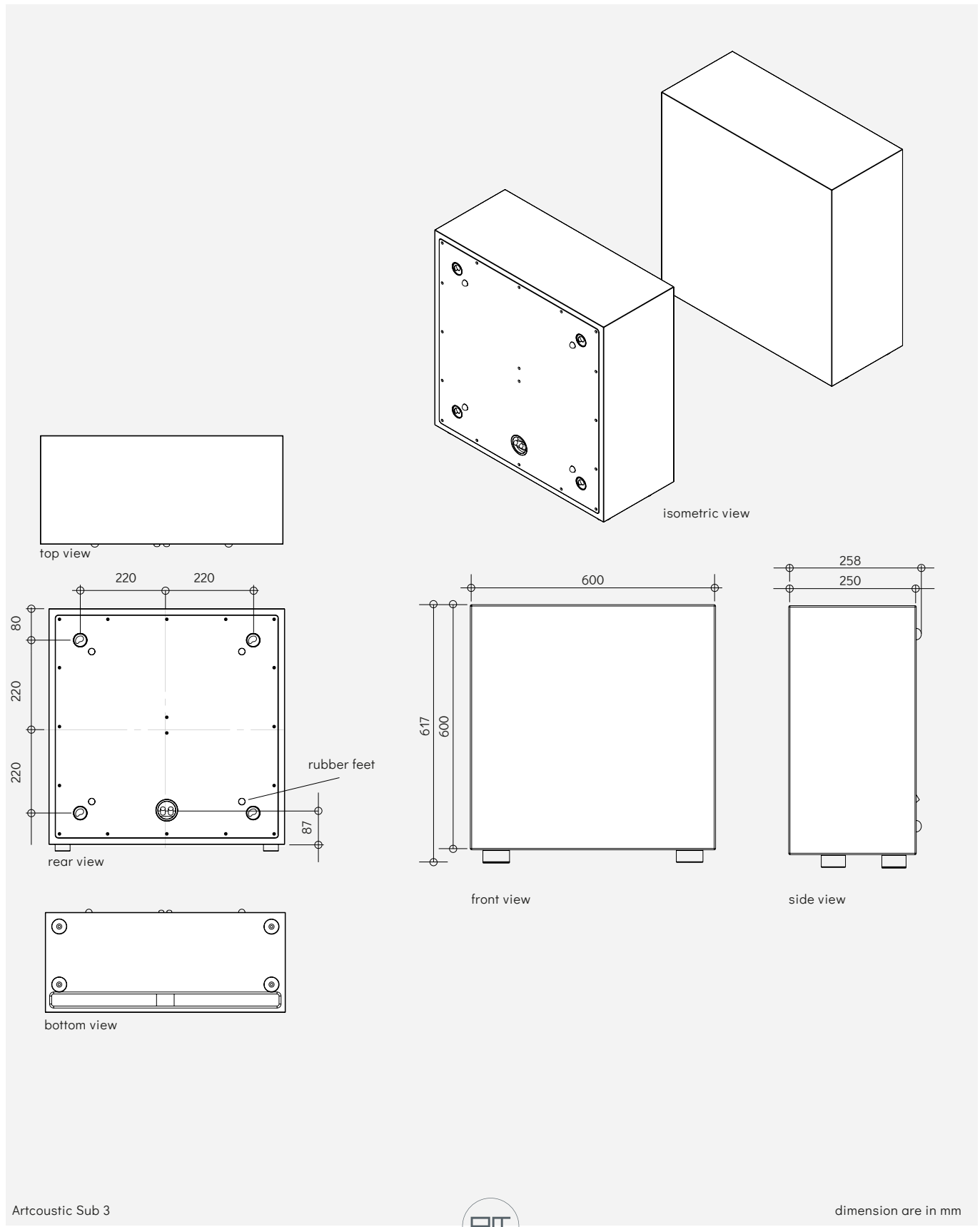

SCHEMATICS

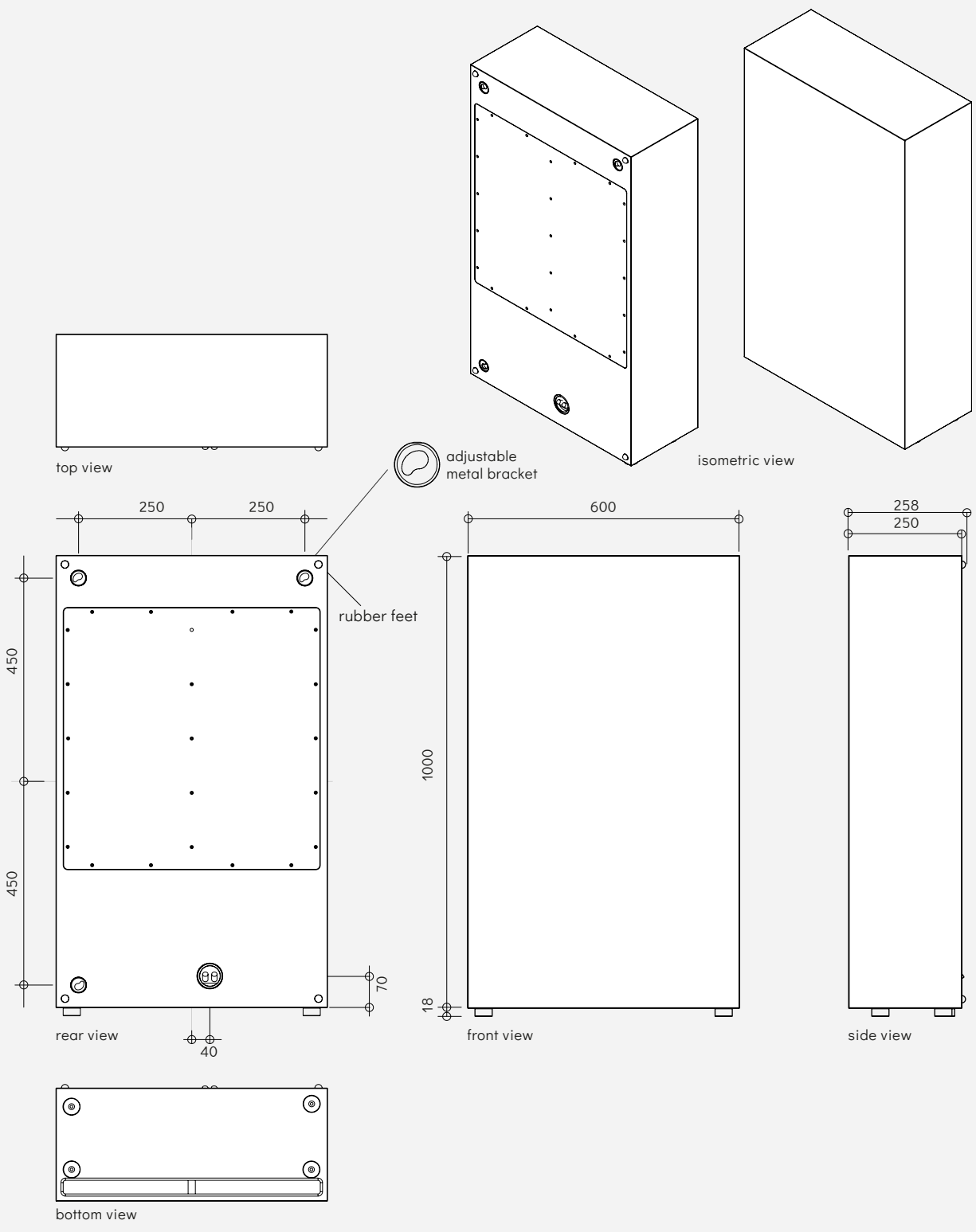

IMPORTANT! DO NOT COVER PORT

MOUNTING INSTRUCTION

IN-WALL SUBWOOFER INSTALLATION MADE EASY

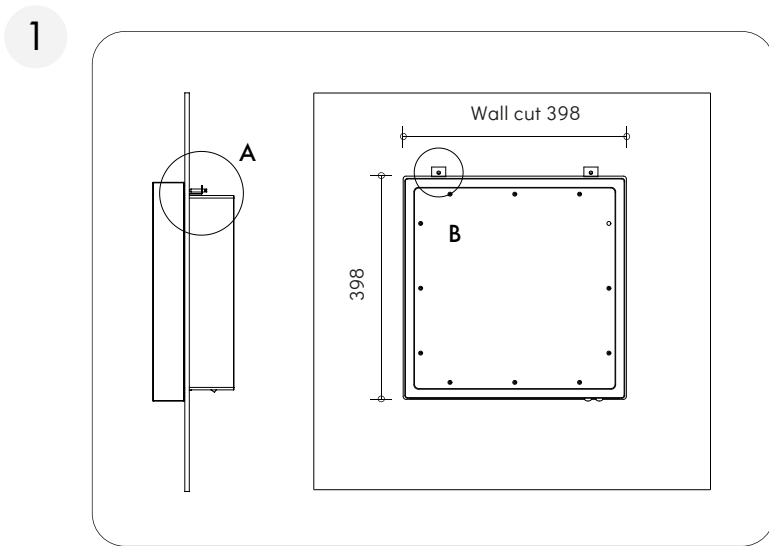

Cut a square hole 398 x 398mm

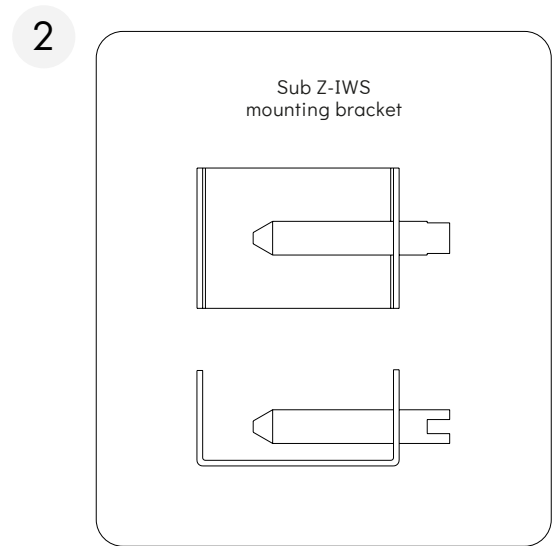

Fix mounting brackets

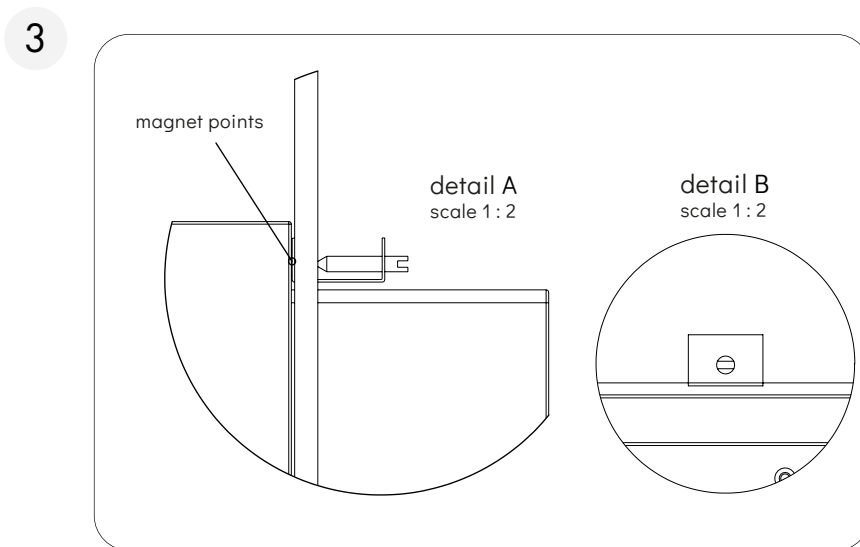

Magnet mount the Sub Z-IWS

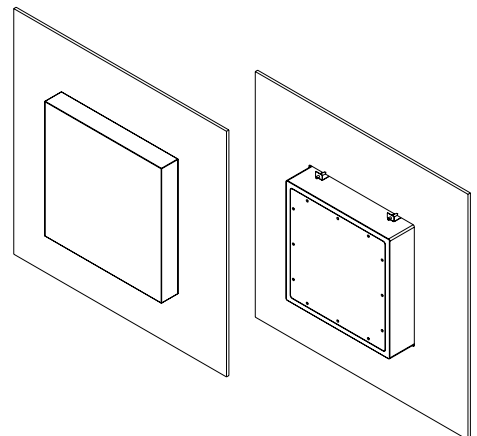

WIRING AND PLACEMENT GUIDE

THE FIRST RANGE OF SUBWOOFER SPECIFICALLY DESIGNED TO HELP ADDRESS ROOM MODES

Artcoustic have helped to create some truly stunning cinema systems, and have used all that experience to develop a groundbreaking range of new subwoofers.

The new SUB Z, SUB Z-IWS, SUB1, SUB2, SUB3, SUB4 effectively allow for more flexibility in positioning your subwoofers.

With this new range, we have the advantage of a smaller design, which here by can be positioned in more suitable places in the room.

This enables us to design systems which address the problematic room modes at the design stage instead of trying to fight them with aggressive EQ once installed.

The end result is a much more dynamic, smoother, more accurate bass in every room.

USE THE NEW SUBWOOFERS IN PAIRS, IN ORDER TO SMOOTHEN OUT
OFTEN DIFFICULT TO EQ ROOM MODES.

SUBWOOFER ROOM SIMULATION

SUB Z SMALL ROOM

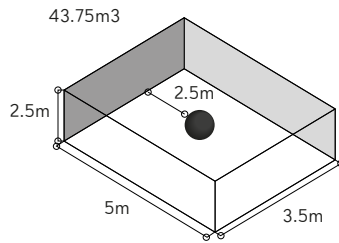

DOLBY ATMOS REFERENCE LEVEL NOT ACHIEVED (-3DB 37HZ)

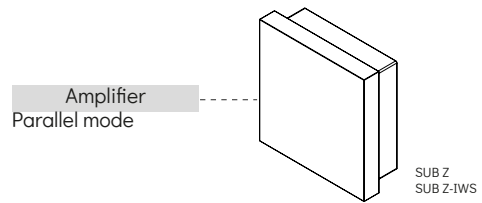
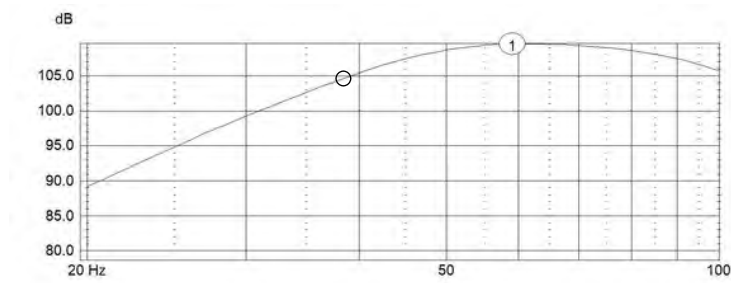

one subwoofer SUBZ/SUB IWS

DOLBY ATMOS REFERENCE LEVEL, ACHIEVED @ 50HZ (-3DB 37HZ)

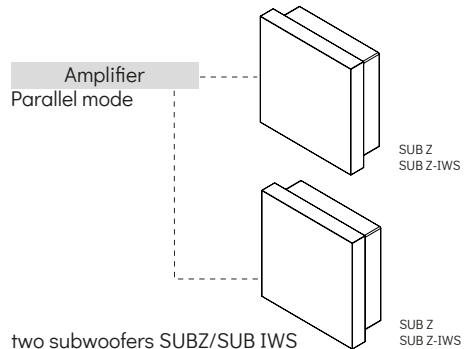
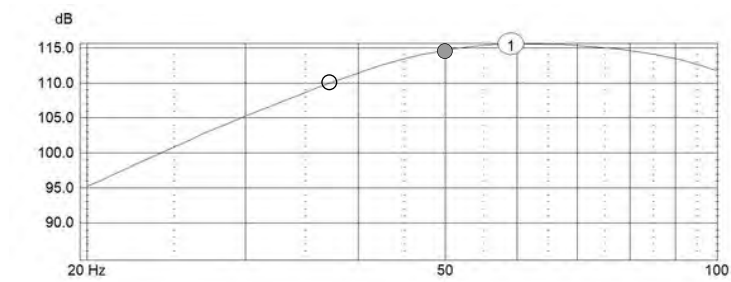

two subwoofers SUBZ/SUB IWS

DOLBY ATMOS REFERENCE LEVEL, ACHIEVED @ 42HZ (-3DB 37HZ)

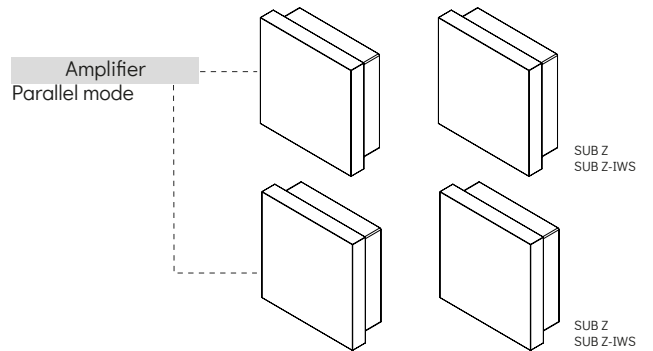
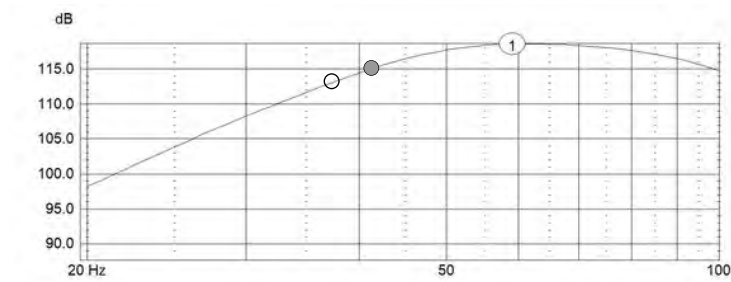

four subwoofers SUBZ/SUB IWS (2-2)

SUBWOOFER ROOM SIMULATION

SUB 1 SMALL ROOM

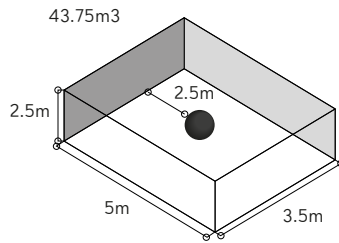

DOLBY ATMOS REFERENCE LEVEL NOT ACHIEVED (-3DB 30HZ)

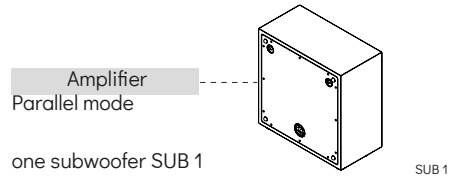
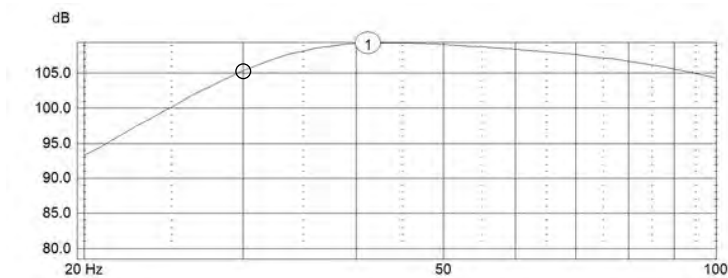

DOLBY ATMOS REFERENCE LEVEL, ACHIEVED @ 40HZ (-3DB 30HZ)

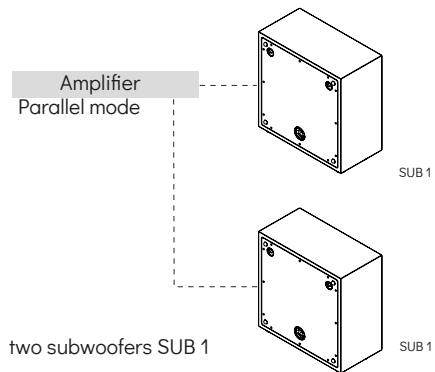
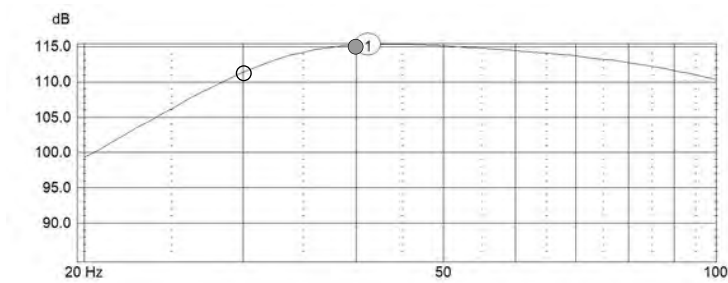

DOLBY ATMOS REFERENCE LEVEL, ACHIEVED @ 32HZ (-3DB 30HZ)

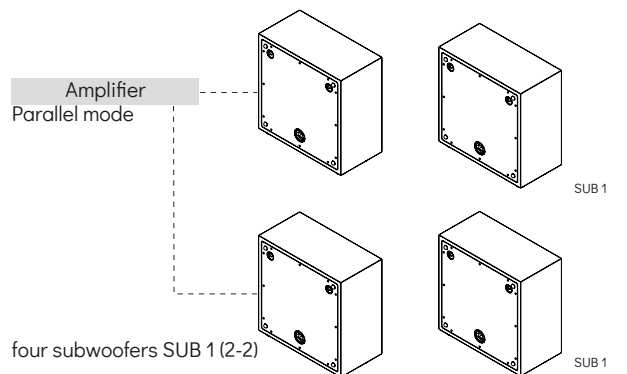
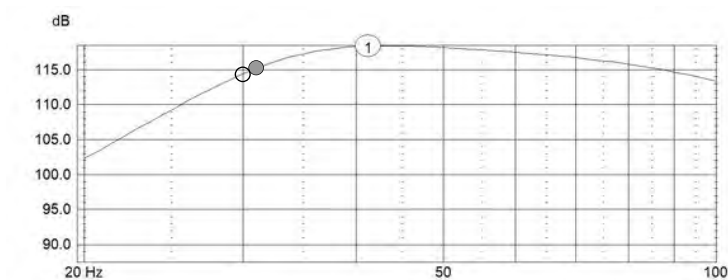

SUBWOOFER ROOM SIMULATION

SUB 2 SMALL ROOM

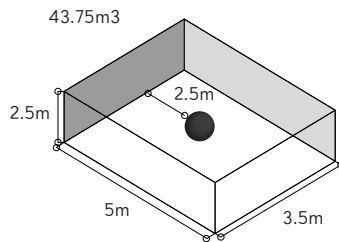

DOLBY ATMOS REFERENCE LEVEL NOT ACHIEVED (-3DB 27HZ)

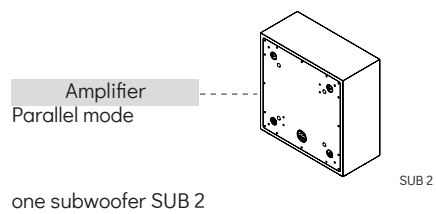
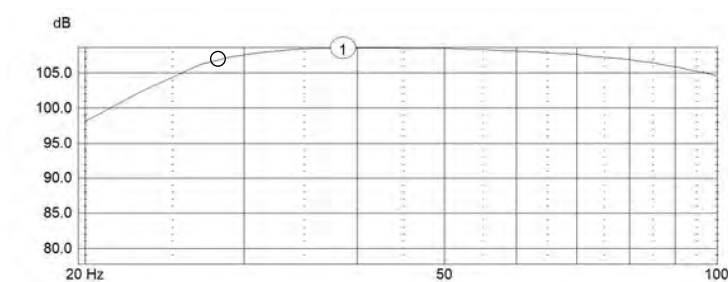

DOLBY ATMOS REFERENCE LEVEL, ACHIEVED @ 35HZ (-3DB 27HZ)

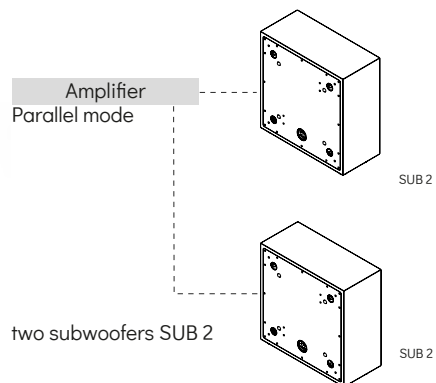
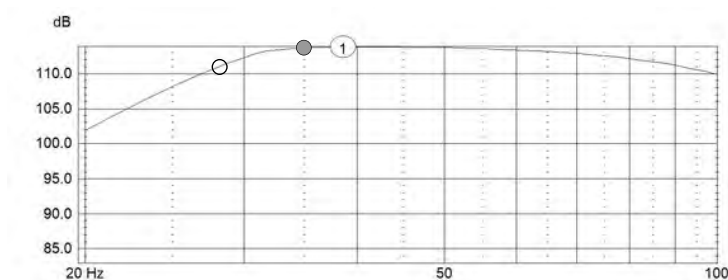

DOLBY ATMOS REFERENCE LEVEL, IN ROOM ACHIEVED @ 29HZ (-3DB 27HZ)

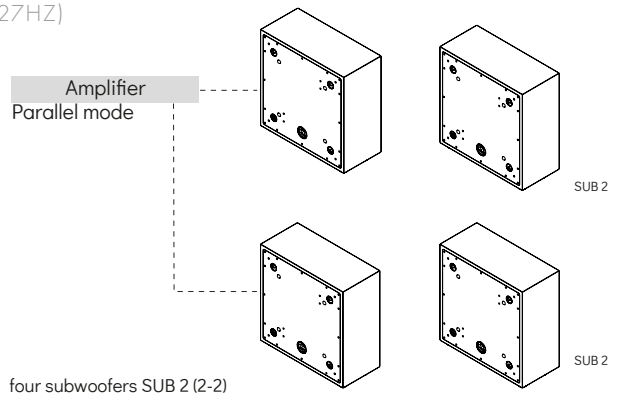
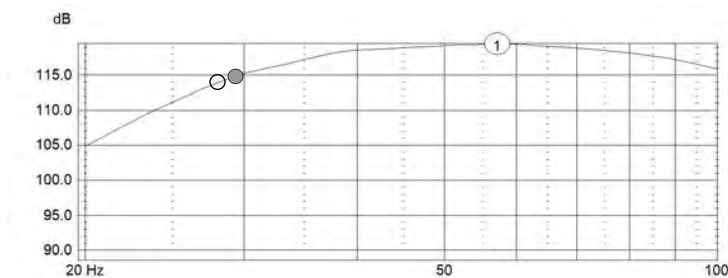

SUBWOOFER ROOM SIMULATION

SUB 3 SMALL ROOM

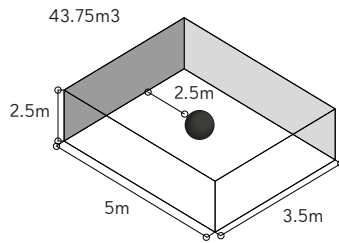

DOLBY ATMOS REFERENCE LEVEL, ACHIEVED @ 33HZ (-3DB 27HZ)

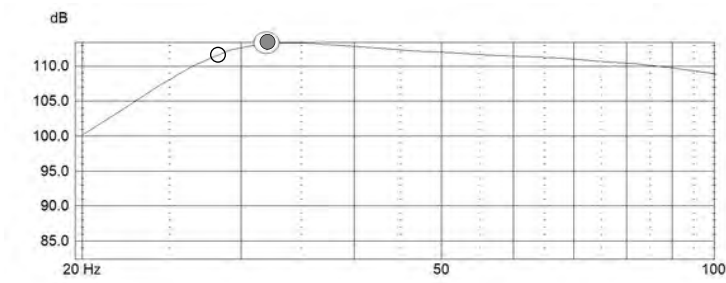

Amplifier
Parallel mode
one subwoofer SUB 3

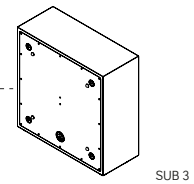

DOLBY ATMOS REFERENCE LEVEL, ACHIEVED @ 28HZ (-3DB 27HZ)

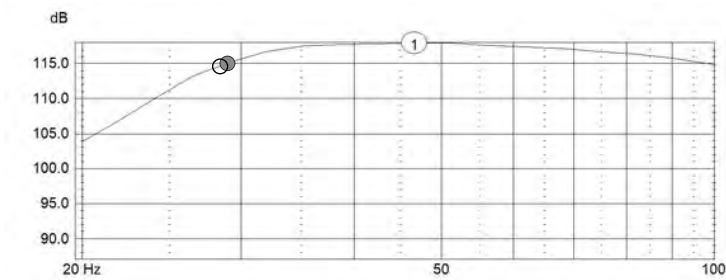

Amplifier
Bridge mode
two subwoofers SUB 3

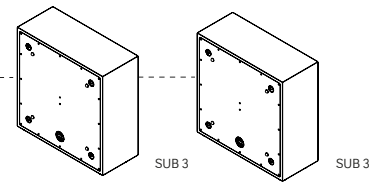

SUBWOOFER ROOM SIMULATION

SUB 2 AND 3 MEDIUM ROOM

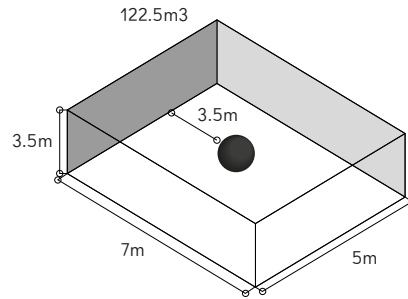

DOLBY ATMOS REFERENCE LEVEL, ACHIEVED @ 35HZ (-3DB 28HZ)

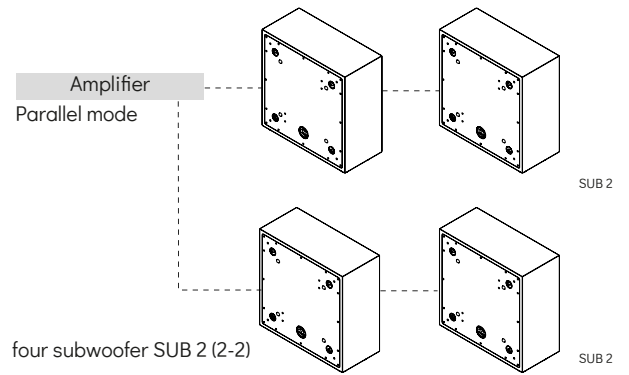
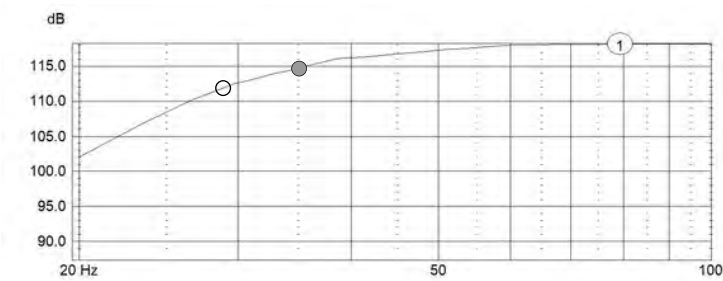

DOLBY ATMOS REFERENCE LEVEL, ACHIEVED @ 35HZ (-3DB 27HZ)

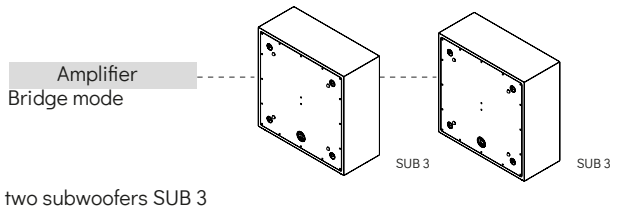
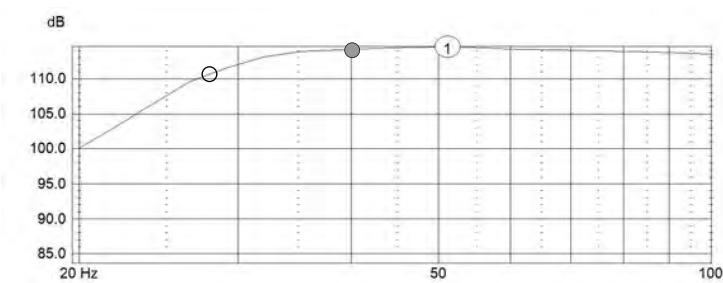

DOLBY ATMOS REFERENCE LEVEL, ACHIEVED @ 30HZ (-3DB 27HZ)

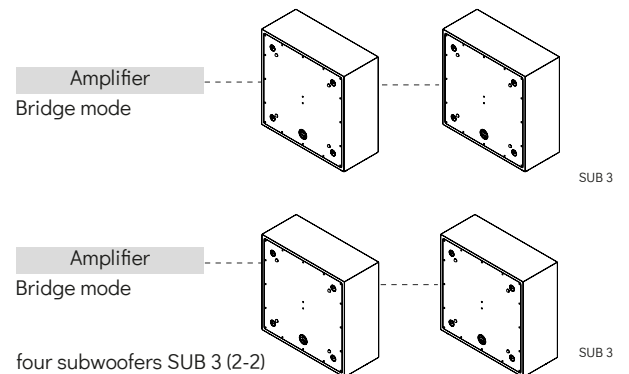
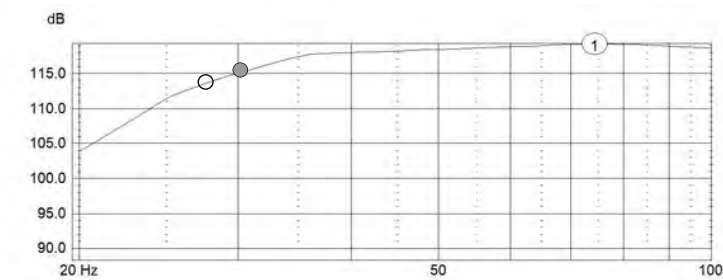

SUBWOOFER ROOM SIMULATION

SUB 4 MEDIUM ROOM

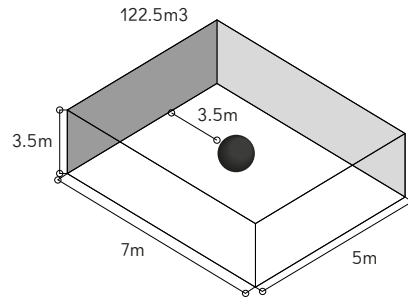

DOLBY ATMOS REFERENCE LEVEL, ACHIEVED @ 35HZ (-3DB 27HZ)

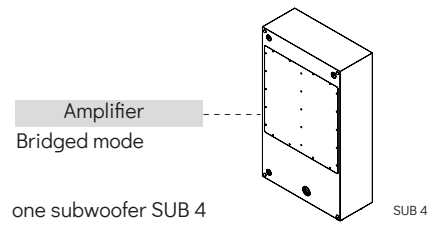
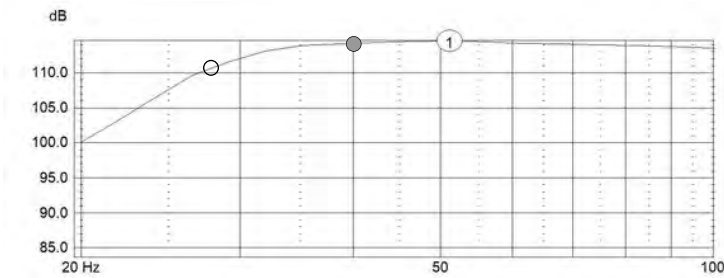

DOLBY ATMOS REFERENCE LEVEL, ACHIEVED @ 30HZ (-3DB 27HZ)

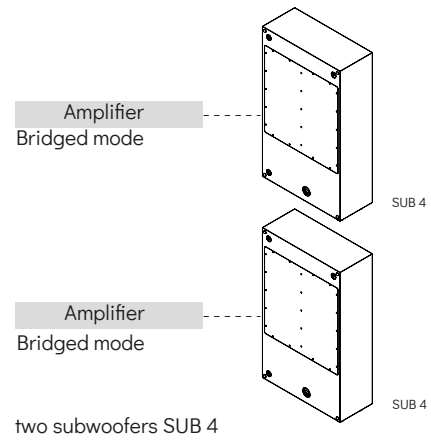
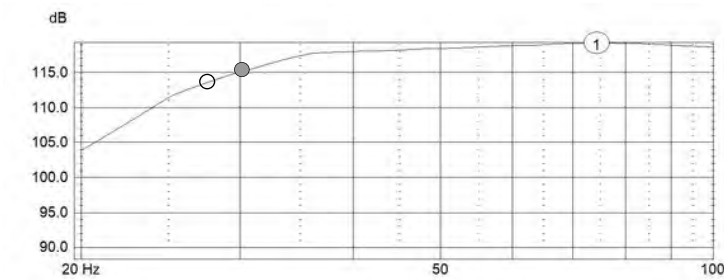

SUBWOOFER ROOM SIMULATION

SUB 3 AND SUB 4 LARGE ROOM

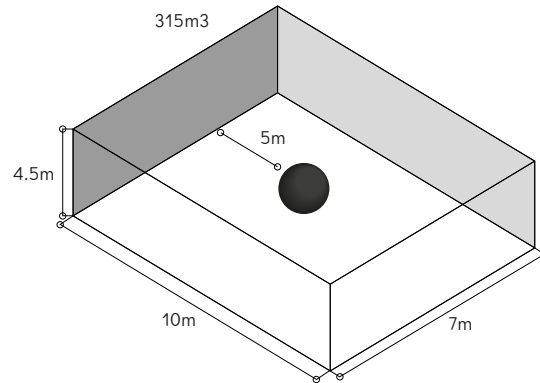

DOLBY ATMOS REFERENCE LEVEL, ACHIEVED @ 35HZ (-3DB 27HZ)

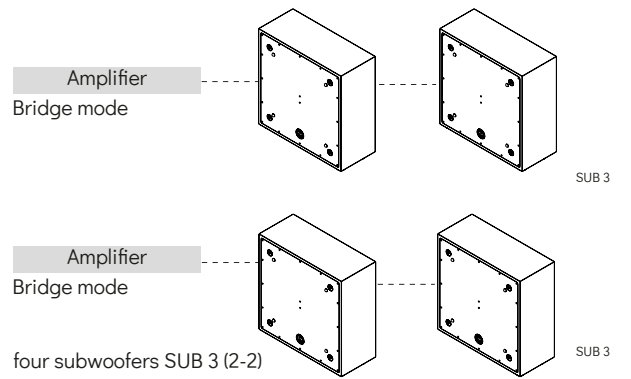
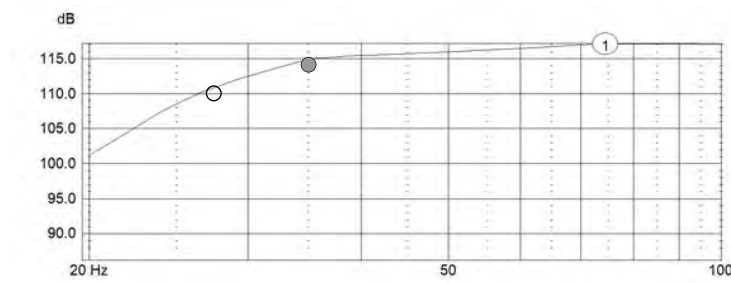

DOLBY ATMOS REFERENCE LEVEL, ACHIEVED @ 35HZ (-3DB 27HZ)

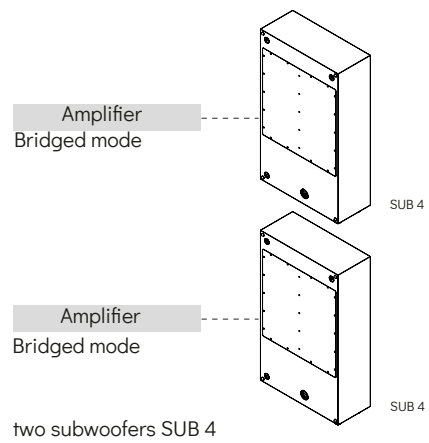
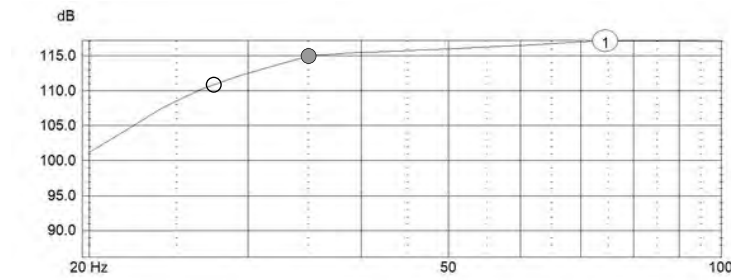

SUBWOOFER PLACEMENT

IMPORTANCE OF ROOM MODES

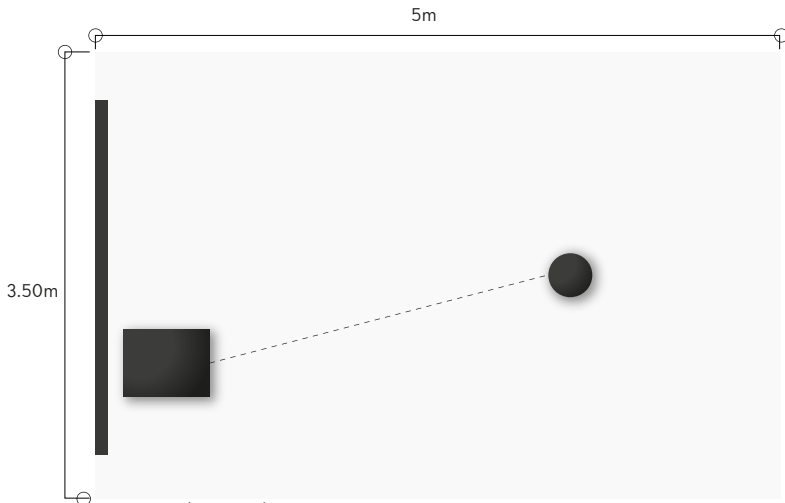

Fig. one sub room placement

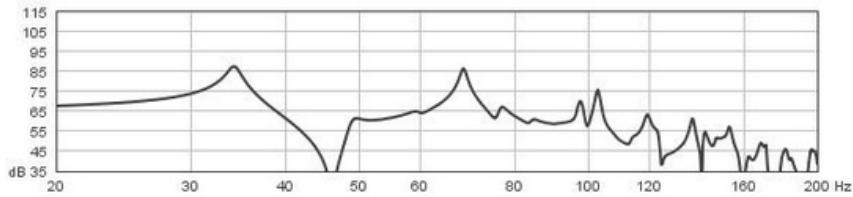

diagram A - frequency response

Diagram A illustrates a typical problem, which can arise using a single or multiple subwoofers, placed in one end of the room.

A rather steep dip can be seen in the region of 35-60Hz.

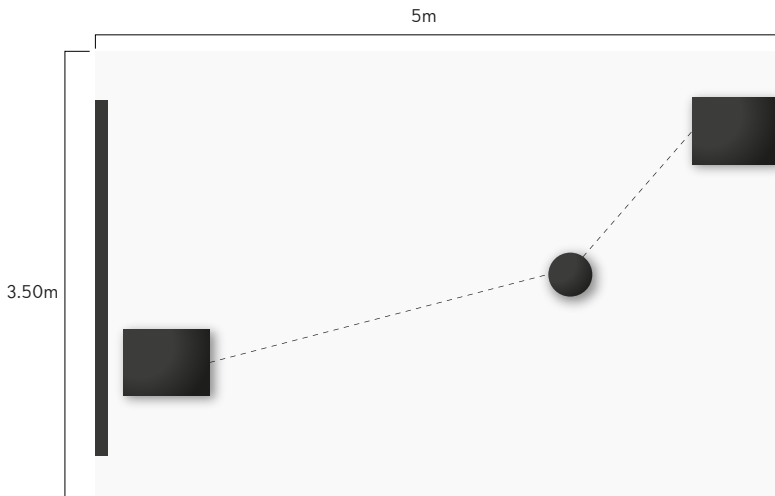

Fig. two sub room placement

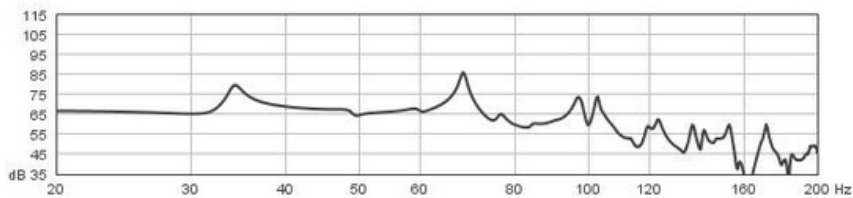

diagram B - frequency response

Diagram B illustrates how a dip can be eliminated by placing a similar size and output subwoofer in the opposite end of the room.

We strongly recommend using multiple subwoofer units whenever budget and space allow for it.

SUBWOOFER PLACEMENT

IMPORTANCE OF ROOM MODES

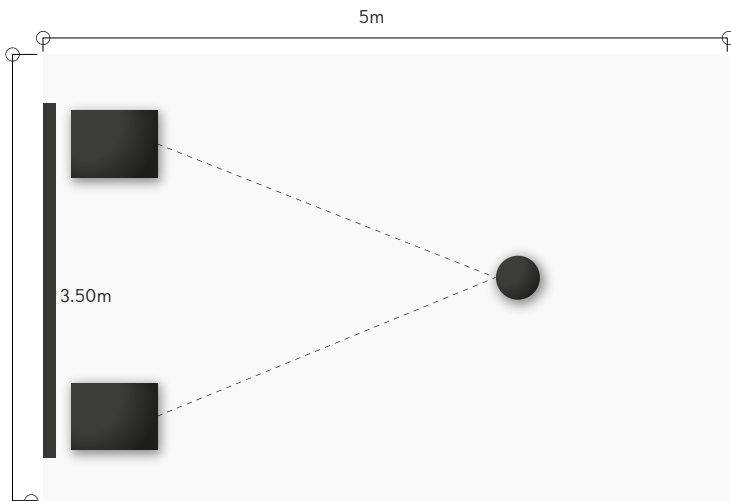

Fig. one sub room placement

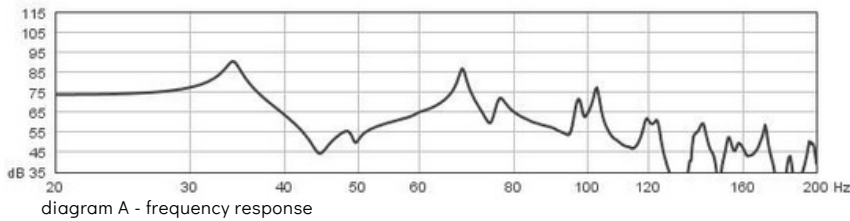

diagram A - frequency response

Diagram A illustrates the same problem, just with multiple units.

Here it can be observed that adding units to same end of room, will only change the overall amplitude, but in no way correcting the room modes causing a dip.

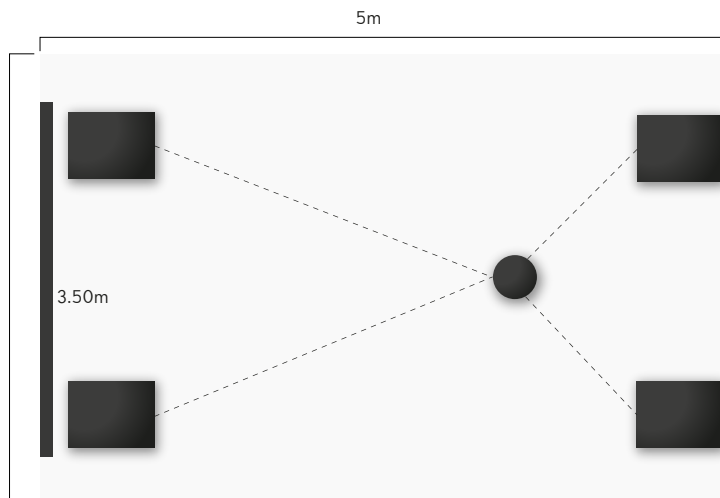

Fig. two sub room placement

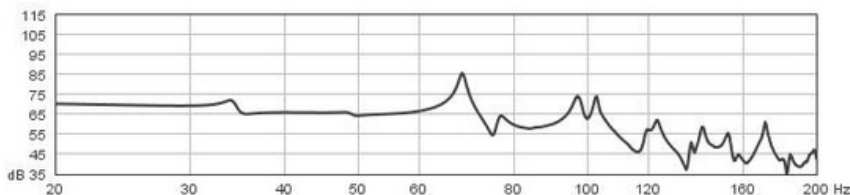

diagram B - frequency response

Again Diagram B illustrates how a dip can be eliminated by placing a similar size and output subwoofers in the opposite end of the room.

And again, we strongly recommend using multiple subwoofer units whenever budget and space allow for it.

It is essential to note that it is not always the best solution to have subwoofers at the front and back, though sometimes it is.

It is entirely room dependant, and that is why Artcoustic will help design systems to ensure the correct subwoofer locations are recommended.

SAFETY INSTRUCTIONS

SAFETY



Do not use this product near water



Clean rear panel with dry cloth only



Do not block any ventilation opening



Do not install near any heat sources

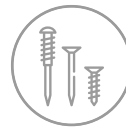

If wall mounted, ensure the use of matching screws and rawl plugs

Refer all servicing to qualified service personnel. Servicing is required when the product has been damaged in any way, such as power-supply cord or plug is damaged, liquid has been spilled or objects have fallen into the product, the product has been exposed to rain or moisture, does not operate normally or has been dropped.

To completely disconnect unit power from the AC mains, disconnect the unit's power cord from the mains socket.

NOTE: If the Artcoustic subwoofer is placed on a thick carpet blocking the air outlet, we recommend to use the special Artcoustic carpet spikes. Not included as standard, please order separately.



WARNING

This product complies with Part 15 of the FCC Rules. Its operation is subject to the following two conditions:

This product may not cause harmful interference.

This product must accept any interference received, including interference that may cause undesired operation.

Changes or modifications not expressly approved by the party responsible for compliance could void the user's authority to operate the equipment.

To reduce the risk of fire and electric shock do not expose this product to rain or moisture.



Do not place product filled with liquids such as vases on the product.



Do not open product. There are no user-serviceable parts inside.



Always use the power supply shipped with this product, using a power supply with wrong voltage or polarity, can damage the electronics.



WARRANTY

IS APPLICABLE



Is valid only for products purchased from an authorised Artcoustic retailer or dealer.



Is valid from the date of purchase for a period of 3-years for passive loudspeakers, and 2-years for powered loudspeakers and electronics.



Is limited to the repair of the equipment (which could be a repair or replacement at our discretion, neither of which affects your original warranty).



Neither transportation, nor any other costs, nor any risk for removal, transportation and installation of products is covered by this warranty.

IS NOT APPLICABLE

Will not be applicable in cases other than defects in materials and/or workmanship at the time of purchase and will not be applicable:

- For deterioration of component parts, the nature of which is to become worn or depleted with use, such as batteries.
- For damages caused by incorrect installation, connection or packing.
- For damages caused by accidents, lightning, water, fire heat, war, public disturbances or any other cause beyond the reasonable control of Artcoustic UK Ltd. and its appointed distributors.
- For damages caused by any use other than correct use described in the user manual, negligence, modifications, or use of parts that are not made or authorized by Artcoustic UK Ltd.

If it is found necessary to return the product for repair, you may be given a Return Merchandise Authorisation. You should not return the product without this authorisation, if given. To validate your warranty, you will need to produce the original sales invoice or other proof of ownership and date of purchase.

The Artcoustic Team