

Eos 
The retina projectors



 **HDR10+**

BLUESCENT
3 000 Lumens Laser Source

HDMI™ 2.1

LOW LATENCY **3D**
 Gaming Mode

8K INTERPOLATION **UHDx** **8K** INTERPOLATION **UHD** **4K** NATIVE RESOLUTION **LCoS**

by **DreamVision**
We dream! We hope! We can!

10 Installation Memories

HDR 10+, 3000 Lumen Laser, HDMI 8K inputs VIDEO-PROJECTORS FOR HOME-CINEMA and SMALL VENUES

8K input and beyond performances

Since 1996, *DreamVision*, in the shadow of the world-famous Montmartre hill in Paris, has been developing and refining the latest advancements in digital display technology in order to provide state-of-the-art video products for Home Cinema. This new projector's chassis was created by the famed French designer, *Antoine Béon*. These shapes are a contemporary work of art that could easily integrate a modern living room. The *Eos Series* are true 4K and 8K performers. Thanks to their three-chips light engine equipped with 4096 x 2160 pixels panels and the exclusive 8K up-scaling algorithms, they can display high-fidelity resolutions up to 8192 x 4320 pixels.

DreamVision also chose the most advanced manufacturing process and luxurious materials for their performances in heat and noise absorption (noise level below 20 dB). The *Eos Series* can be ordered in black or white as standard, but can also be ordered with any custom RAL paint and finish.



***The Eos 1 Family, Eos 2-L, Eos 3-L (on the left) and the Eos Signature-L (on the right).
The Eos Series can be ordered with any custom RAL paint.***

Dedicated to sharp pictures and precision, the *Eos Series* come with an improved *Low Latency* mode that drastically reduces the motion blur and enhances the thrill when playing video games or viewing virtual reality show and simulations. The *Low Latency* mode is seconded by the *Crystal Motion®* algorithm which is a frame interpolation method that brings an immersive experience to sport, concerts or TV shows.

Laser Light source up to 3000 Lumens

This year, *DreamVision* brings the *Eos Series* projectors a to new level with the integration of a new Laser LED. The laser bank is more reliable, more powerful and possess a longer longevity and larger color spectrum than traditional lamps. Thanks to the exclusive BLUEscent technology, you will enjoy continuous 20,000 hours. The light dimming can be controlled with a slight delay. It allows the reproduction of images closer to the human perception and attaining infinity:1 dynamic contrast ratio.

BLUEscent
3 000 Lumens Laser Source

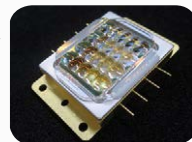

The Eos Signature-L, UHD-X Interpolation and LD Lenses

Sharpness is not only a matter of pixels or resolution, but also it depends on other elements such as the lens purity, the up-scaling quality or the light source. When using Laser light source, the picture obtained is sharper. The *Eos Signature-L* also comes with a large, 100 mm diameter optic made with Low-Dispersion lenses that further enhances the picture sharpness. The *Eos 2-L* and *Eos Signature-L* also comes with an amazing 8K 4-Way Interpolation algorithm called UHD-X that is capable to upscale perfectly any lower quality sources up to 8K resolution.



The Eos Signature-L picture extreme picture sharpness is obtained by combining Laser Light source, high quality optical elements with an amazing 8K 4-Way UHD interpolation and Low Latency computations.

HDR 10+ content with two dynamic tone mappings

The *Eos Series Series* are capable of reproducing the rich video information of High Dynamic Range (HDR) contents, including extended brightness range, wide color gamut such as BT.2020.

In addition to the HDR10 format used in UHD Blu-ray and streaming, as well as the Hybrid Log Gamma format used in broadcasting, the Eos Series now support the high level picture quality HDR10+ format, with two dynamic tone mappings and Frame Adapt HDR. This, coupled with the Laser technology, allows the *Eos Series* to achieve the optimum contrast, even at high frame rates, bringing a truer to life picture to your screen.

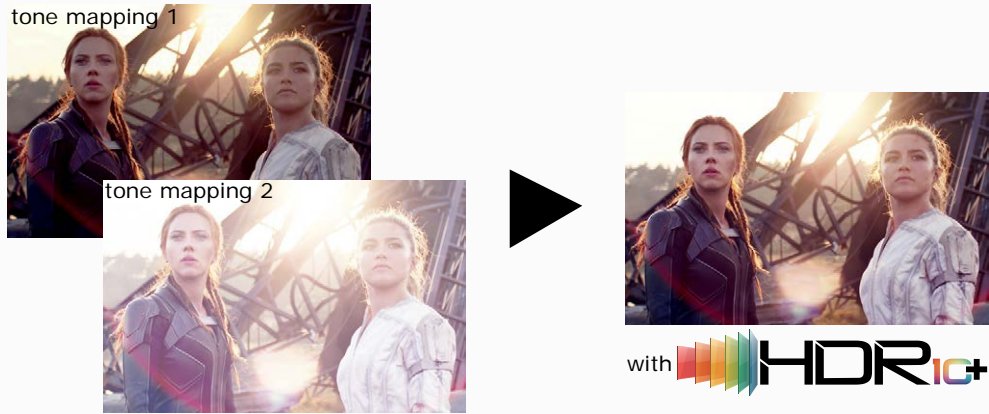

Result of HDR10+ rendition with two dynamic tone mappings

When it comes to HDR contents, any lack of precision would be unforgiveable and would lead to disastrous results on the screen. This is why the HDR support is continuously improved and the *Eos Series* has a new dedicated interface with special color profile to finely tune the HDR parameters.

Versatility and Ease of Installation

In addition to their impressive performances, the Eos Series projectors are easily installed. The input panel at the back of the projector, offers two hdmi inputs. The large zoom, combined with an electronic lens shift, will allow for perfect adjustment in virtually any residential installations. With the fully motorized and remote controlled lens, the installation becomes easier and faster. The *Eos Series Series* have a $\pm 80\%$ vertical shift and the $\pm 34\%$ horizontal shift. And if that is not enough, either you can opt for a *Eos Signature-L* model that has a larger vertical shift up to $\pm 100\%$ and $\pm 43\%$ horizontal shift or you can use the crisp, high quality Keystone correction.

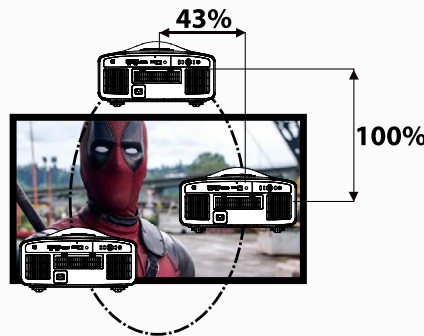

The Eos Signature-L is the most versatile of the Eos Series thanks to its 43% vertical shift and 100% horizontal shift.

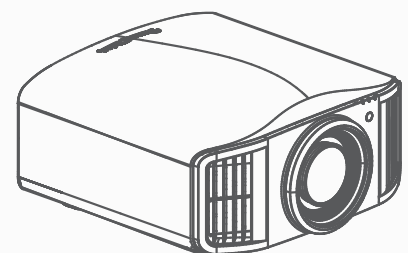
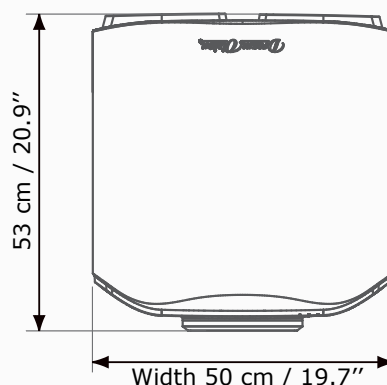
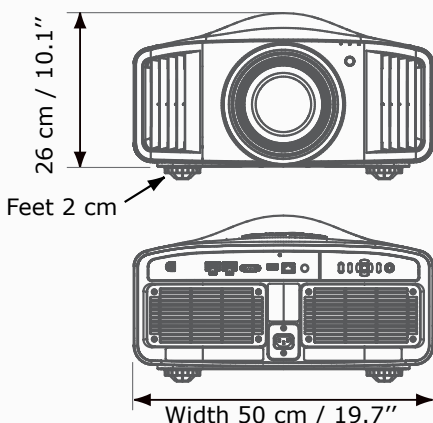

Weight up to 28 kg (61.7 lbs)

Model	Eos Family	Eos 1-L	Eos 2-L	Eos Signature-L
Standard Pack	R9202200	R9202201	R9202202	R9202203
Panel Resolution	3 x 4 096 x 2 160 (4K Resolution)			
Panel Technology	3-chip LCOS 0.69" panels		3-chip LCOS 0.69" panels with Ultra-High Contrast Optics	
Display Resolution	4 096 x 2 160 (4K without interpolation)	8 192 x 4 320 (8K with UHD Interpolation)	8 192 x 4 320 (8K with <i>UHD-X</i> Interpolation)	
Signal Compatibility	UHD Blu-ray up to 4K120p HDR10+ content HLG streaming services HFR gaming Consoles	UHD Blu-ray disks up to 8K60p / 4K120p HDR 10+ content with 2 dynamic tone mappings and Frame Adapt HDR HLG (Hybrid Log Gamma) broadcasting and streaming services High Frame Rate and Low Latency gaming Consoles		
Optic	Standard Full-glass 65 mm Lens (2x zoom)		High-Quality, 8K-optimized, 100 mm diameter Lens with Low Dispersion elements (2x Zoom)	
Throw Ratio (16:9)	Motorized zoom: 1.44:1 - 2.88:1		Motorized zoom: 1.37:1 - 2.74:1	
Screen Offset (16:9)	Motorized lens shift: ±80% vertically ±34% horizontally		Motorized lens shift: ±100% vertically ±43% horizontally	
Screen Size	60" - 200" diagonal		60" - 300" diagonal	
Lamp Consumption	265 W NSH Bulb	BLUEScent Laser Diode - up to 20 000 hours or 20 years (no replacement needed)		
Brightness	1 900 Lumens	2 200 Lumens	2 500 Lumens	3 000 Lumens
Native Contrast Ratio	40 000:1	40 000:1	80 000:1	100 000:1
Dynamic Contrast Ratio	400 000:1	Infinity:1		
Color Modes	REC.709 (HDTV)		REC.709, wide gamut, DCI-P3 and BT.2020	
Expert Calibration	Yes (for calibration expert only)			
Picture Modes	4 Presets + Film + 6 Users + 2 Installation Expert only		4 Presets + Film + 6 Users + 4 Installation Expert only	
Color Space Profiles	9 Presets + 6 Customs		10 Presets + 6 Customs	
Noise Level	Less than 22 dB (in low mode)			
Inputs	1x HDMI 2.1 (with HDCP 2.3 and 48 Gbps transmission band) 1x HDMI 2.0b (with HDCP 2.2 and 18 Gbps transmission band)			
Home-cinema Video Processing	HDR10+ Auto-Tone mapping EOTF and Hybrid Log gamma HDR Picture modes with Perceptual Quantization (PQ) HDR colorimetry and MaxCLL / MaxFALL meta-data Low Latency/Game mode @120Hz gaming experiences Blur Reduction, 400 Hz Crystal Motion® Theater Optimizer Function		HDR10+ Auto-Tone mapping EOTF and Hybrid Log gamma HDR Picture modes with Perceptual Quantization (PQ) HDR colorimetry and MaxCLL / MaxFALL meta-data Low Latency/Game mode @120Hz gaming experiences Blur Reduction, 400 Hz Crystal Motion® Theater Optimizer Function DCI-P3 and BT.2020 Color Profiles	
3D Compatibility	Frame Packing, Side-by-Side, Top & Bottom			
Home Automation Control	RS-232 (Dsub 9) / LAN RJ45 / 12V Trigger (100mA)			
Power and Consumption	AC 110~240V 50/60Hz 420 W 0.3W in Standby Eco-Mode 1.5W with LAN		AC 110~240V 50/60Hz 440 W 0.3W in Standby Eco-Mode 1.5W with LAN	
Dimensions (WxHxD)	50 x 26 x 49.5 cm (19.7" x 10.1" x 19.5")	50 x 26 x 50.5 cm (19.7" x 10.1" x 19.9")	50 x 26 x 53 cm (19.7" x 10.1" x 20.9")	
Box dimensions (LxWxH)	66 x 65 x 44 cm - 30 kg (66.1 lbs)			
Weight	23 kg (50.7 lbs)	26 kg (57.3 lbs)	28 kg (61.7 lbs)	
3D options	RF Active Shutter 3D glasses (R1048223) RF 3D Dongle (R1048229)			
Ceiling Mounts	Fixed Position (R9852068) Motorized 1 meter Lift (M9201400) Motorized 2 meters Lift (M9201404)			
Other options	Cinemascope Lens, special colors and finishes on demand or RAL, Passive 3D Glasses.			