

Artcoustic^{AI}

SL EVOLVE SERIES

Owners manual

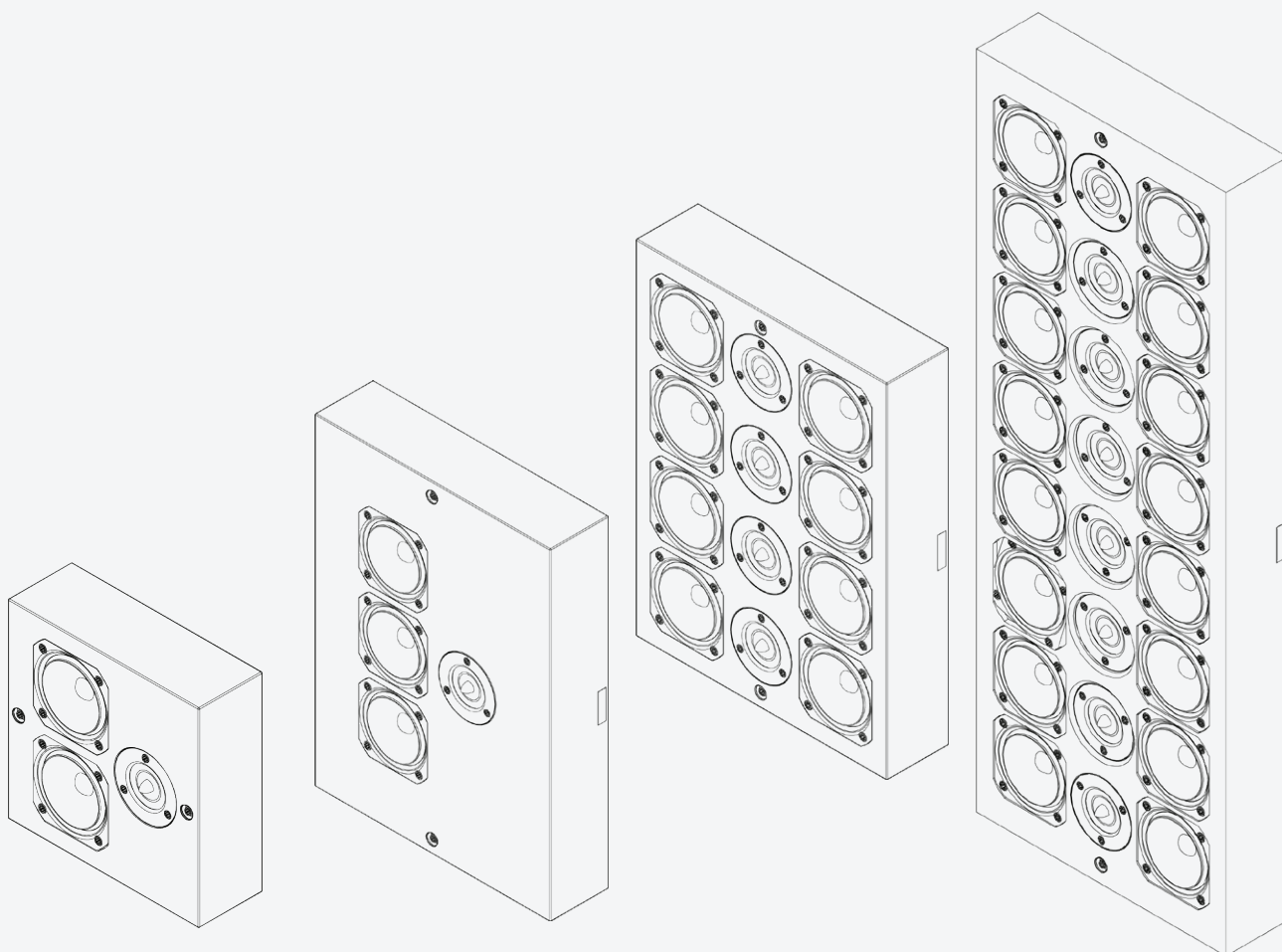

WELCOME TO THE WORLD OF ARTCOUSTIC

Congratulations on your purchase of the Artcoustic SL Evolve Series.

The SL Evolve Series is Artcoustic's most versatile range of products. Its slimline profile, combined with a powerful and articulated performance, makes it the ideal choice for high-end cinema, Hi-Fi and, multi-room audio installations. For an even more impressive performance, partner it with one of the Artcoustic subwoofers - an ideal setup for small and medium-size cinema rooms.

The SL Evolve Series has been engineered to produce exceptional sound pressure level, normally only associated with typical professional audio products, and has been designed to ensure the utmost aesthetic residential pleasing options, all combined with literally thousands of cabinet and front screens colours.

The SL Evolve Series is a true all-rounder, whether you are looking for high-end sound from two speakers in a stereo music setup, or multiple speakers for cinemas and multi-room audio, the SL Evolve Series will fulfill all your audio needs.

Thank you for purchasing the Artcoustic SL Evolve Series.

All the best,
The Artcoustic Team

FEATURES

SL EVOLVE SERIES

At Artcoustic, our product development team are always looking for innovative and groundbreaking ways to improve our products. We continually invest a huge amount of time and effort to make sure that Artcoustic delivers products at the top of their class, with regards to technological excellence and refined Scandinavian design.

Introducing the latest edition of the SL Evolve series – the Evolve Time Aligned Array (ETAA). The ETAA is a precise and well-designed solution for dealing with high-frequency array phase overlap. By carefully placing high-frequency transducers within a mathematical and geometric calculated formula, the acoustically impossible is now possible.

The design has been optimised to allow the product to achieve a near-perfect response curve, without compromising on any of the existing high-end features including extreme sound pressure levels, sensitivity, extended frequency response, controlled directivity, exceptional speed, and transient response. All arranged within a well-designed, slimline cabinet.

ETAA ADVANTAGES

EXTENDED FLAT FREQUENCY RESPONSE UP TO 40 KHZ

DETAILED AND TRANSPARENT SWEET SPOT,
with an almost magical ability of making the actual speakers acoustically disappear.

A SOPHISTICATED AND MINIMAL CABINET DESIGN
with endless options to customise your speaker. Choose from an unlimited range of colours, matching screen covers or select your own artwork.

HIGH SENSITIVITY AND EXCEPTIONAL SOUND PRESSURE LEVEL

LOW DISTORTION

BENCH MARK TRANSIENT RESPONSE

GUIDED DIRECTIVITY
with near perfect response curve +/- 3 dB over long distances

PLUG AND PLAY EASY TO INSTALL APPROACH
eliminating installation mistakes and misunderstandings

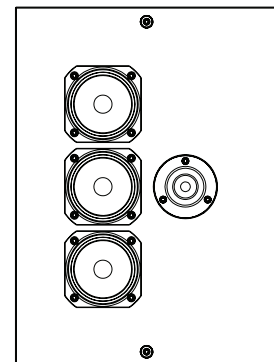

SL Evolve 3-1 front view

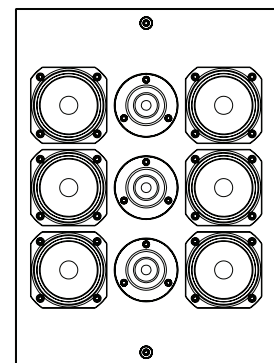

SL Evolve 6-3 front view

Overall, the ETAA delivers incredible detail and airy sound that typical high-end Hi-Fi speakers only offer at short distances. The Artcoustic ETAA delivers above and beyond providing a throw distance of well beyond 40 meters making this product a natural evolution within the Artcoustic portfolio of industry-leading products.

FEATURES

SL EVOLVE 1-1

This multi-purpose monitor shares many characteristics with the other models in the Evolve range. Maintaining Artcoustic's clean contemporary design, the SL Evolve 1-1 has been designed to match all modern flat screen monitors.

SL Evolve 1-1 - This is a very flexible loudspeaker, designed for use in smaller rooms for home cinema or HiFi, and multi-room applications in kitchens, bedrooms, studies, etc.

EXTREMELY SMALL AND COMPACT CABINET DESIGN

LOW DISTORTION

LOW POWER CONSUMPTION

WIDE FREQUENCY RESPONSE 70 HZ TO 40 KHZ

FAST, EASY AND SIMPLE INSTALLATION

SUITABLE FOR A WIDE RANGE OF APPLICATION,
from HiFi Systems, Multi Room Systems and smaller Home
Cinemas

Ultra-slim aesthetically pleasing cabinet design, designed
to complement the latest LED screen designs

Choose from a vast range of colour options from NSC and RAL to match your cabinet colour and screen to your interior. Artcoustic has created a true all-rounder, covering most medium SPL applications, where high performance and aesthetics is a focal point.

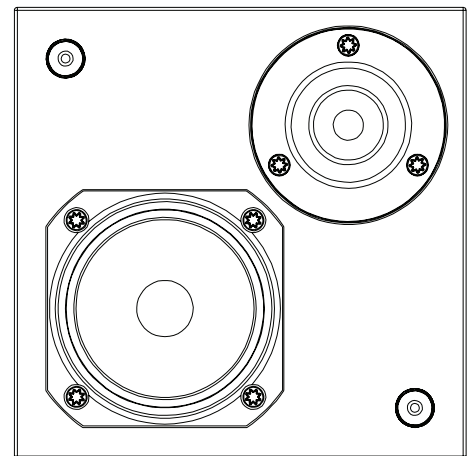

front view

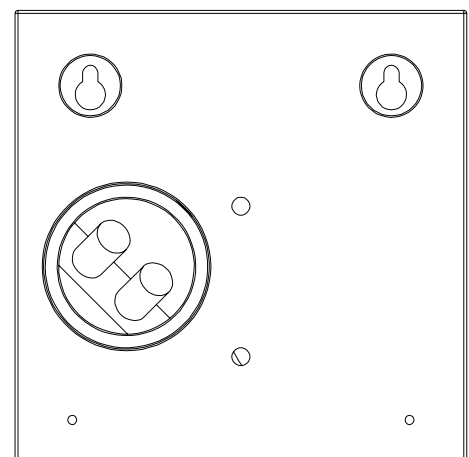

rear view

FEATURES

SL EVOLVE 2-1

This multi-purpose monitor shares many characteristics with the other models in the Evolve range. Maintaining Artcoustic's clean contemporary design, the SL Evolve 2-1 has been designed to match all modern flat screen monitors.

The SL Evolve 2-1 is a very flexible loudspeaker, designed for use in smaller rooms for home cinema or HiFi, as well as for multi-room applications in kitchens, bedrooms, studies, etc.

PHASE OPTIMISATION AND CONTROLLED FREQUENCY OVERLAP BASS SYSTEM, EXTENDED LOW FREQUENCY

EXTREMELY SMALL AND COMPACT CABINET DESIGN

LOW DISTORTION

LOW POWER CONSUMPTION

WIDE FREQUENCY RESPONSE 70 HZ TO 40 KHZ

FAST, EASY AND SIMPLE INSTALLATION

SUITABLE FOR A WIDE RANGE OF APPLICATION, from HiFi Systems, Multi Room Systems and smaller Home Cinemas

Ultra-slim aesthetically pleasing cabinet design, designed to complement the latest LED screen designs

Choose from a vast range of colour options from NSC and RAL to match your cabinet colour and screen to your interior. Artcoustic has created a true all-rounder, covering most medium SPL applications, where high performance and aesthetics is a focal point.

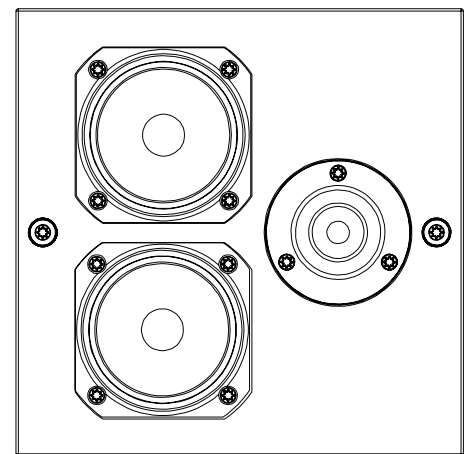

front view

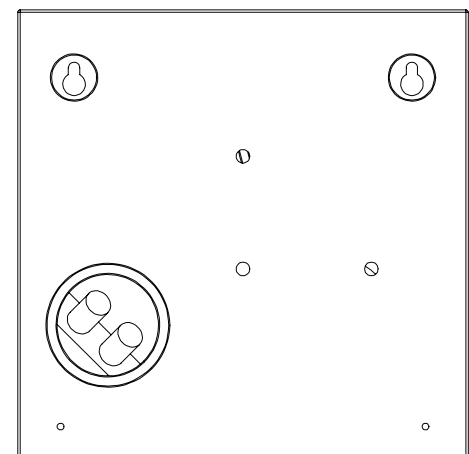

rear view

FEATURES

COMPONENTS OVERVIEW

WOOFER

Extra long excursion and aluminium Short Circuiting Ring, 4-layer voice coil, anodised aluminium for improved heat dissipation, combined with Distortion Reduced Motor.

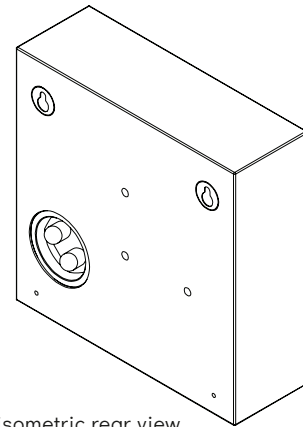

isometric rear view

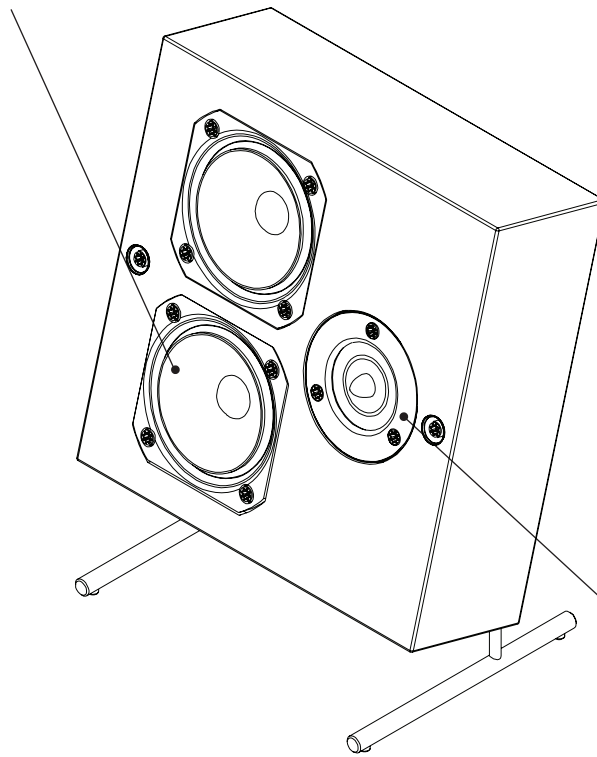

SL Evolve 2-1 isometric front view

CROSSOVER

6 dB/octave low pass and 12 dB/octave high pass filter.

HIGH FREQUENCY DRIVER

Dual Ring Radiator diaphragm with highly linear suspension and low loss surrounds for high clarity and clean transient response. Copper caps for better HF extension and lower distortion and wave-guide center plug, copper-clad aluwire.

FEATURES

COMPONENTS OVERVIEW

HIGH FREQUENCY DRIVER

Dual Ring Radiator diaphragm with highly linear suspension and low loss surrounds for high clarity and clean transient response. Copper caps for better HF extension and lower distortion and wave-guide center plug, copper-clad aluwire.

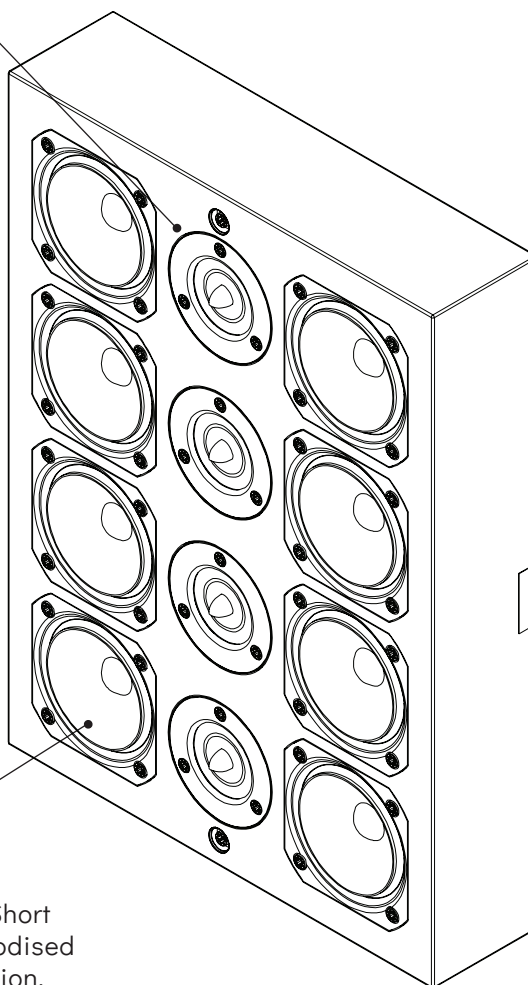

SL Evolve 8-4 isometric view

WOOFER

Extra long excursion and aluminium Short Circuiting Ring, 4-layer voice coil, anodised aluminium for improved heat dissipation, combined with Distortion Reduced Motor.

CROSSOVER

6 dB/octave low pass and 12 dB/octave high pass filter.

SPECIFICATIONS

SL EVOLVE 1-1

TRANSDUCER

LF-MF 1 x 3 inch cone

HF 1 x 1 inch Dual Ring Radiator

CROSSOVER

Low Pass Filter 6 dB/octave 1000 Hz

High Pass Filter 12 dB/octave 4000 Hz

CONNECTION

Single amped Gold Plated Push Terminals

PERFORMANCE

Operating Range 70 Hz (-3dB) to 40 kHz

Axial Sensitivity (Half Space SPL) LF/MF-HF 89 dB

Calculated Axial Output Limit (Half Space SPL) Average Peak 104 dB

Maximum Power Handling 30 Watt

Input Impedance Nominal 7 ohms

Nominal Beamwidth Horizontal 90° Vertical 90°

Recommended High Pass Filter 100 Hz, 24 dB/octave

DESIGN

Cabinet: Black, White, RAL, NCS.

Screen: Black, White, RAL, NCS, Artcoustic Art Gallery

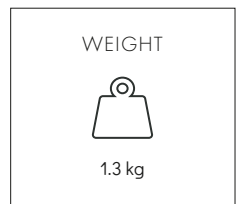
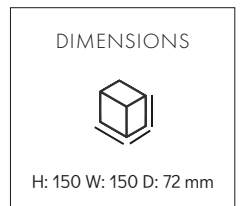
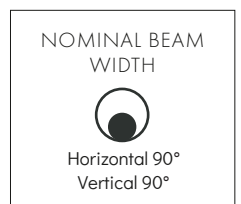
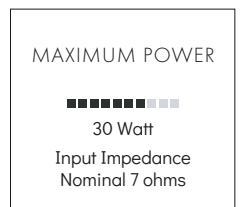
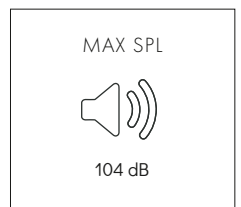
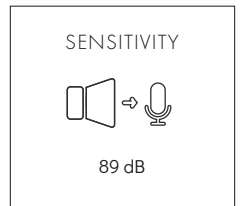

SPECIFICATIONS

SL EVOLVE 2-1

TRANSDUCER

LF-MF 2 x 3 inch cones

HF 1 x 1 inch Dual Ring Radiator

CROSSOVER

Low Pass Filter 6 dB/octave 1000 Hz

High Pass Filter 12 dB/octave 4000 Hz

CONNECTION

Single amp'd Gold Plated Push Terminals

PERFORMANCE

Operating Range 55 Hz (-3dB) to 40 kHz

Axial Sensitivity (Half Space SPL) LF/MF-HF 91 dB

Calculated Axial Output Limit (Half Space SPL) Average Peak 108 dB

Maximum Power Handling 60 Watt

Input Impedance Nominal 4 ohms

Nominal Beamwidth Horizontal 90° Vertical 90°

Recommended High Pass Filter 100 Hz, 24 dB/octave

DESIGN

Cabinet: Black, White, RAL, NCS.

Screen: Black, White, RAL, NCS, Artcoustic Art Gallery

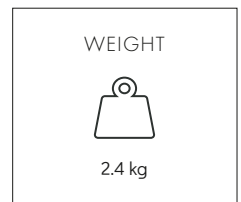
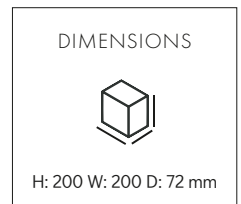
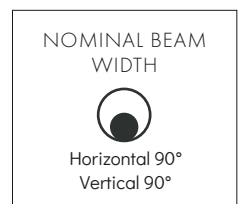
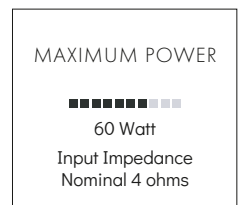
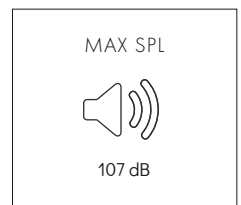
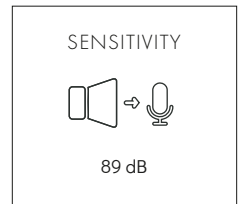
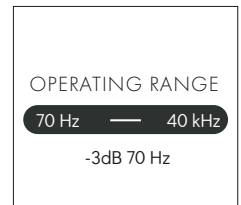

SPECIFICATIONS

SL EVOLVE 3-1

TRANSDUCER

LF-MF 3 x 3 inch cones, Symmetric Phase Aligned
HF 1 x 1 inch Dual Ring Radiator, Symmetric Phase Aligned

CROSSOVER

Low Pass Filter 6 dB/octave 1000 Hz
High Pass Filter 12 dB/octave 4000 Hz

CONNECTION

Single amp'd Gold Plated Push Terminals

PERFORMANCE

Operating Range 60 Hz (-3dB) to 40 kHz
Axial Sensitivity (Half Space SPL) LF/MF-HF 94 dB
Calculated Axial Output Limit (Half Space SPL) Average Peak 108 dB
Maximum Power Handling 90 Watt
Input Impedance Nominal 4 ohms
Nominal Beamwidth Horizontal 80° Vertical 80°

Recommended High Pass Filter 100 Hz, 24 dB/octave

DESIGN

Cabinet: Black, White, RAL, NCS.
Screen: Black, White, RAL, NCS, Artcoustic Art Gallery

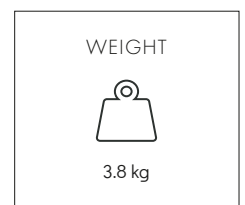
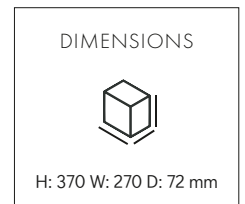
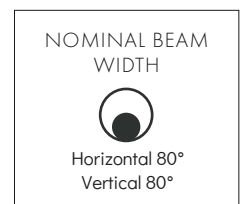
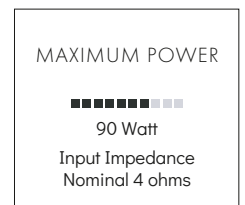
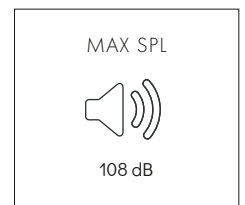
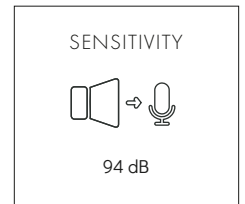
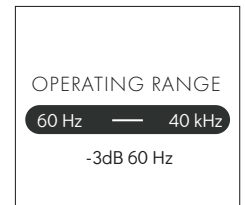

SPECIFICATIONS

SL EVOLVE 4-2

TRANSDUCER

LF-MF 4 x 3 inch cones, Symmetric Phase Aligned
HF 2 x 1 inch Dual Ring Radiator, Symmetric Phase Aligned

CROSSOVER

Low Pass Filter 6 dB/octave 1000 Hz
High Pass Filter 12 dB/octave 4000 Hz

CONNECTION

Single amp'd Gold Plated Push Terminals

PERFORMANCE

Operating Range 60 Hz (-3dB) to 40 kHz
Axial Sensitivity (Half Space SPL) LF/MF-HF 96 dB
Calculated Axial Output Limit (Half Space SPL) Average Peak 114 dB
Maximum Power Handling 120 Watt
Input Impedance Nominal 4 ohms
Nominal Beamwidth Horizontal 80° Vertical 40°

Recommended High Pass Filter 100 Hz, 24 dB/octave

DESIGN

Cabinet: Black, White, RAL, NCS.
Screen: Black, White, RAL, NCS, Artcoustic Art Gallery

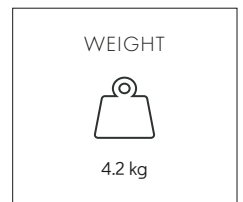
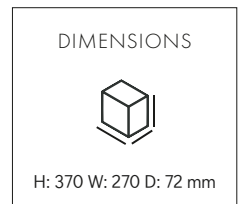
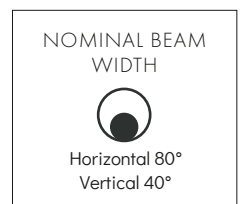
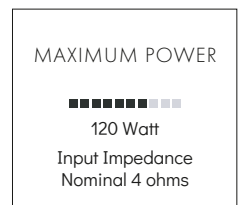
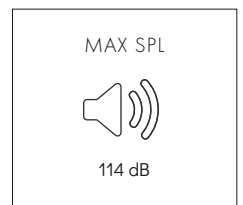
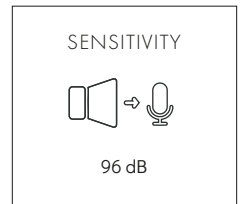
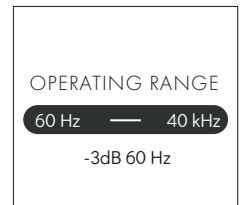

SPECIFICATIONS

SL EVOLVE 6-3

TRANSDUCER

LF-MF 6 x 3 inch cones, Symmetric Phase Aligned
HF 3 x 1 inch Dual Ring Radiator, Symmetric Phase Aligned

CROSSOVER

Low Pass Filter 6 dB/octave 1000 Hz
High Pass Filter 12 dB/octave 4000 Hz

CONNECTION

Single amped Gold Plated Push Terminals

PERFORMANCE

Operating Range 65 Hz (-3dB) to 40 kHz
Axial Sensitivity (Half Space SPL) LF/MF-HF 98 dB
Calculated Axial Output Limit (Half Space SPL) Average Peak 119 dB
Maximum Power Handling 180 Watt
Input Impedance Nominal 5 ohms
Nominal Beamwidth Horizontal 80° Vertical 30°

Recommended High Pass Filter 100 Hz, 24 dB/octave

DESIGN

Cabinet: Black, White, RAL, NCS.
Screen: Black, White, RAL, NCS, Artcoustic Art Gallery

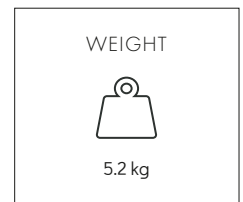
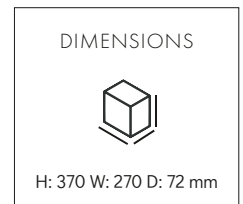
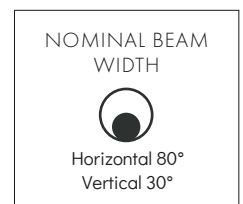
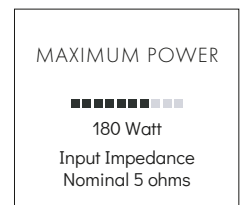
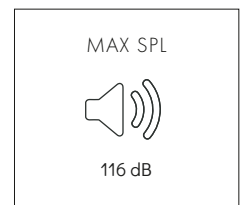
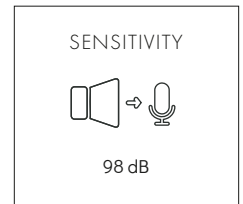
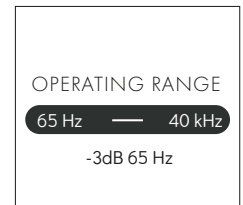

SPECIFICATIONS

SL EVOLVE 8-4

TRANSDUCER

LF-MF 8 x 3 inch cones, Symmetric Phase Aligned
HF 4 x 1 inch Dual Ring Radiator, Symmetric Phase Aligned

CROSSOVER

Low Pass Filter 6 dB/octave 1000 Hz
High Pass Filter 12 dB/octave 4000 Hz

CONNECTION

Single amped Gold Plated Push Terminals

PERFORMANCE

Operating Range 70 Hz (-3dB) to 40 kHz
Axial Sensitivity (Half Space SPL) LF/MF-HF 99 dB
Calculated Axial Output Limit (Half Space SPL) Average Peak 123 dB
Maximum Power Handling 240 Watt
Input Impedance Nominal 3.5 ohms
Nominal Beamwidth Horizontal 80° Vertical 25°

Recommended High Pass Filter 100 Hz, 24 dB/octave

DESIGN

Cabinet: Black, White, RAL, NCS.
Screen: Black, White, RAL, NCS, Artcoustic Art Gallery

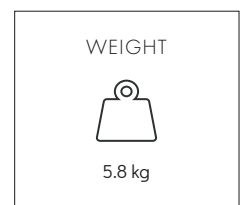
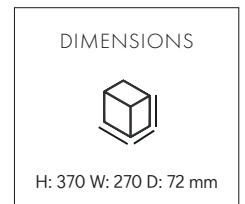
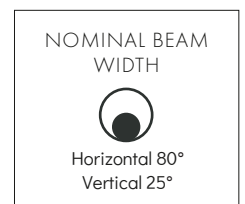
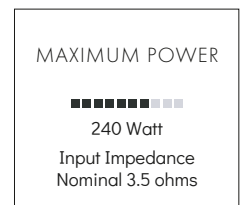
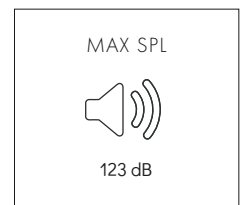
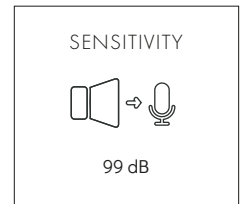
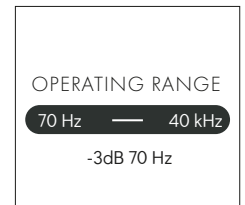

SPECIFICATIONS

SL EVOLVE 12-6

TRANSDUCER

LF-MF 12 x 3 inch cones, Symmetric Phase Aligned
HF 6 x 1 inch Dual Ring Radiator, Symmetric Phase Aligned

CROSSOVER

Low Pass Filter 6 dB/octave 1000 Hz
High Pass Filter 12 dB/octave 4000 Hz

CONNECTION

Single amped Gold Plated Push Terminals

PERFORMANCE

Operating Range 65 Hz (-3dB) to 40 kHz
Axial Sensitivity (Half Space SPL) LF/MF-HF 101 dB
Calculated Axial Output Limit (Half Space SPL) Average Peak 124 dB
Maximum Power Handling 360 Watt
Input Impedance Nominal 7 ohms
Nominal Beamwidth Horizontal 80° Vertical 20°

Recommended High Pass Filter 100 Hz, 24 dB/octave

DESIGN

Cabinet: Black, White, RAL, NCS.
Screen: Black, White, RAL, NCS, Artcoustic Art Gallery

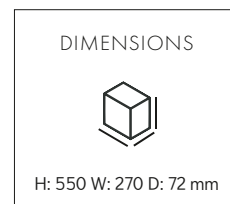
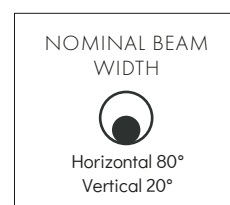
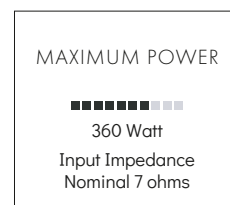
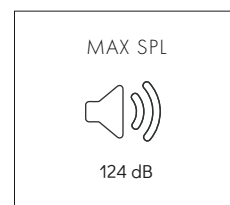
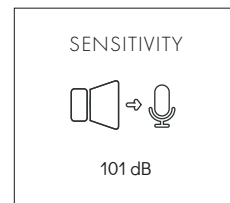
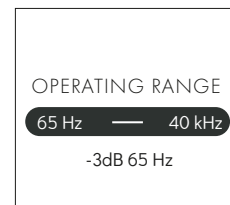

SPECIFICATIONS

SL EVOLVE 16-8

TRANSDUCER

LF-MF 16 x 3 inch cones, Symmetric Phase Aligned
HF 8 x 1 inch Dual Ring Radiator, Symmetric Phase Aligned

CROSSOVER

Low Pass Filter 6 dB/octave 1000 Hz
High Pass Filter 12 dB/octave 4000 Hz

CONNECTION

Single amped Gold Plated Push Terminals

PERFORMANCE

Operating Range 75 Hz (-3dB) to 40 kHz
Axial Sensitivity (Half Space SPL) LF/MF-HF 103 dB
Calculated Axial Output Limit (Half Space SPL) Average Peak 126 dB
Maximum Power Handling 480 Watt
Input Impedance Nominal 7 ohms
Nominal Beamwidth Horizontal 80° Vertical 18°

Recommended High Pass Filter 100 Hz, 24 dB/octave

DESIGN

Cabinet: Black, White, RAL, NCS.
Screen: Black, White, RAL, NCS, Artcoustic Art Gallery

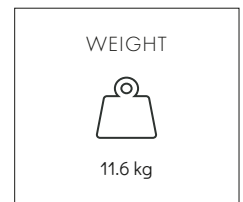
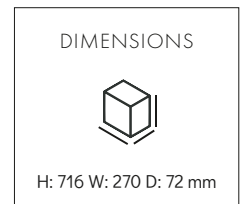
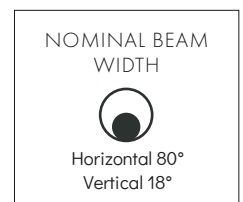
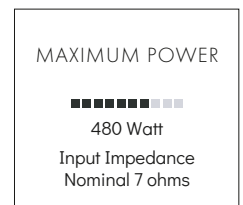
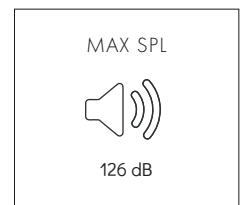
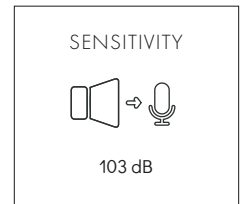
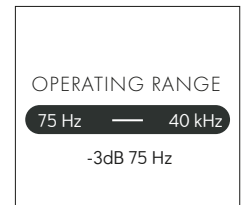

SPECIFICATIONS

SL EVOLVE 24-12

TRANSDUCER

LF-MF 24 x 3 inch cones, Symmetric Phase Aligned
HF 12 x 1 inch Dual Ring Radiator, Symmetric Phase Aligned

CROSSOVER

Low Pass Filter 6 dB/octave 1000 Hz
High Pass Filter 12 dB/octave 4000 Hz

CONNECTION

Single amped Gold Plated Push Terminals

PERFORMANCE

Operating Range 75 Hz (-3dB) to 40 kHz
Axial Sensitivity (Half Space SPL) LF/MF-HF 107 dB
Calculated Axial Output Limit (Half Space SPL) Average Peak 130 dB
Maximum Power Handling 720 Watt
Input Impedance Nominal 5 ohms
Nominal Beamwidth Horizontal 80° Vertical 17°

Recommended High Pass Filter 100 Hz, 24 dB/octave

DESIGN

Cabinet: Black, White, RAL, NCS.
Screen: Black, White, RAL, NCS, Artcoustic Art Gallery

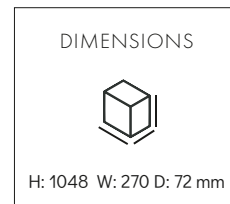
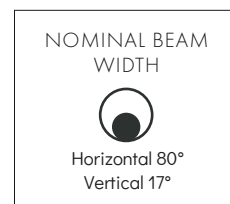
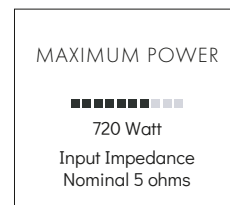
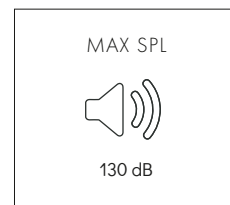
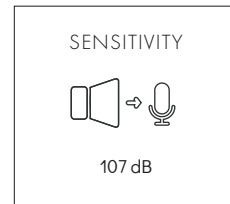
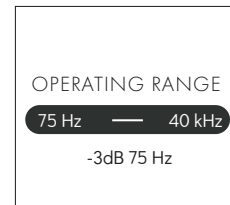

SCHEMATICS

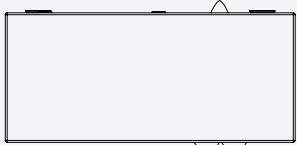

bottom view

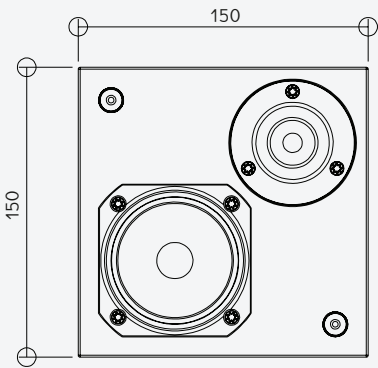
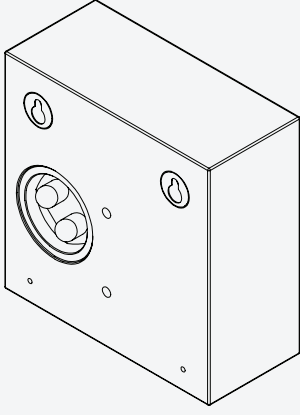
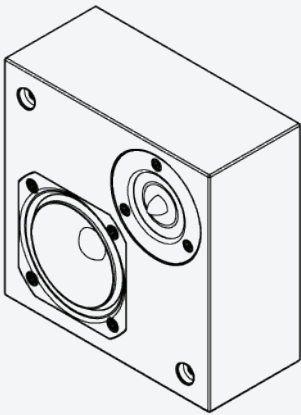

front view

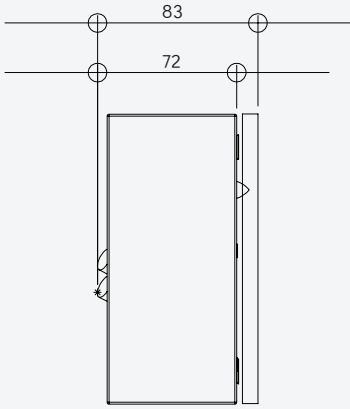

side view

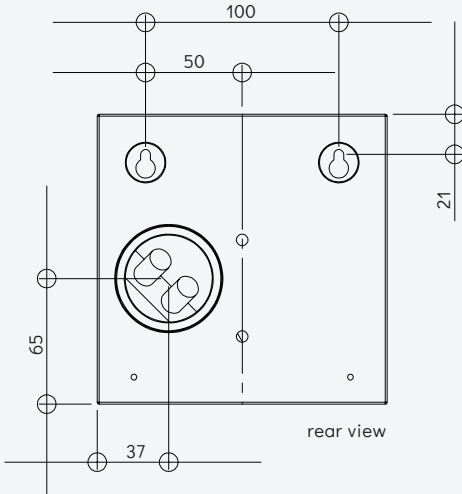

rear view

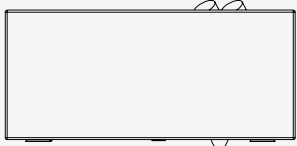

top view

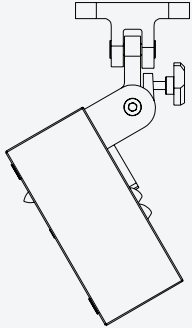
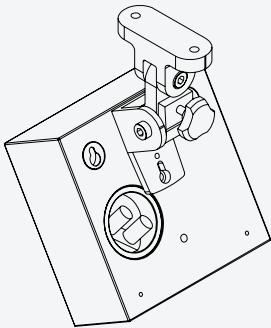
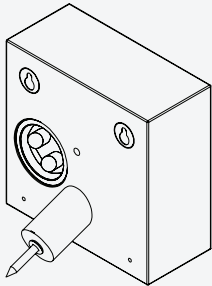

SCHEMATICS



bottom view

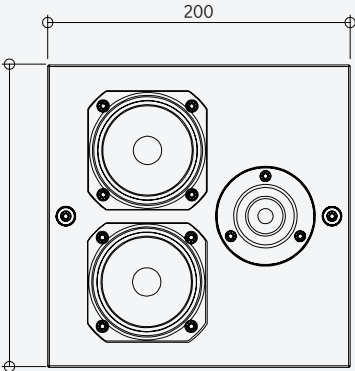

front view



top view

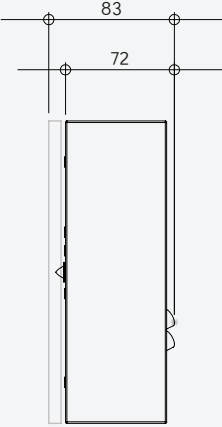
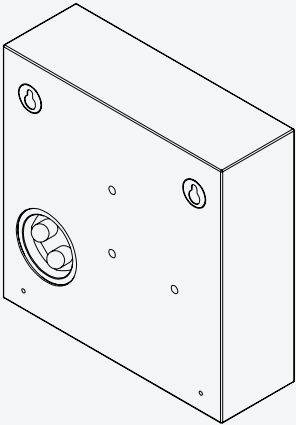
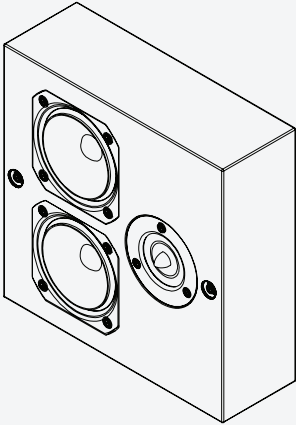

side view

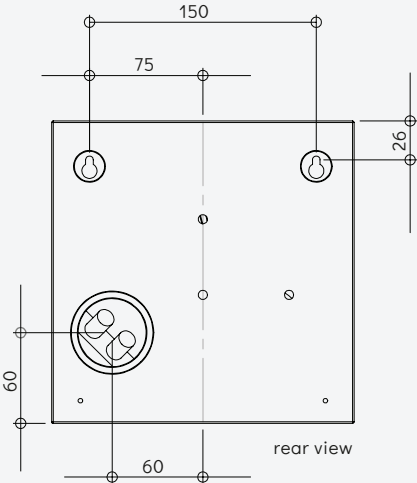

rear view

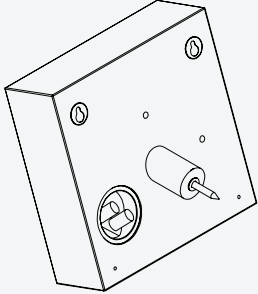
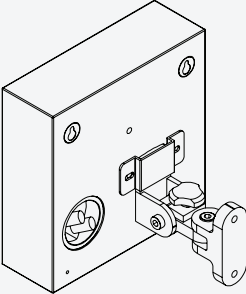
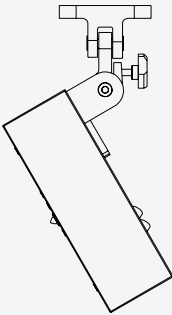
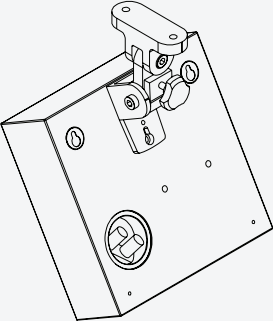

SCHEMATICS

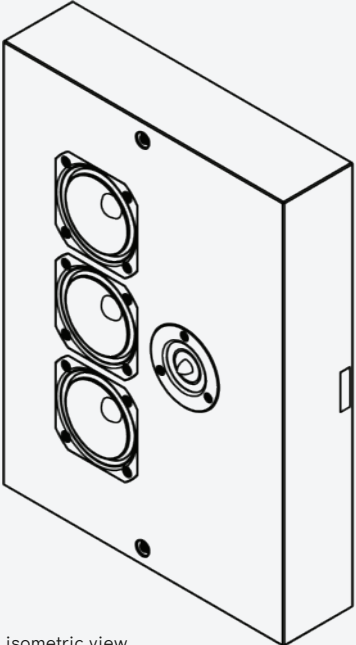

isometric view



top view

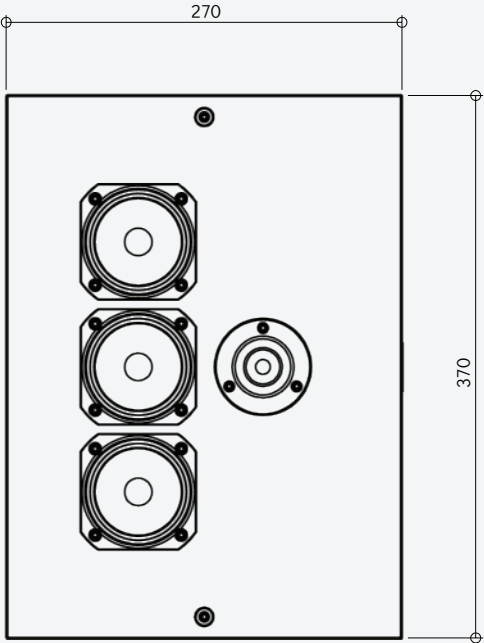

front view

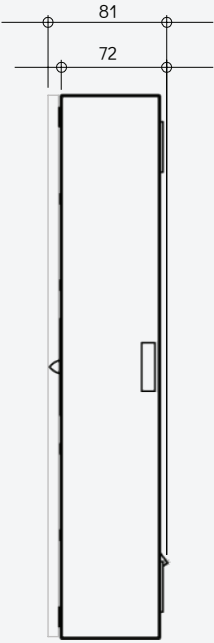

side view

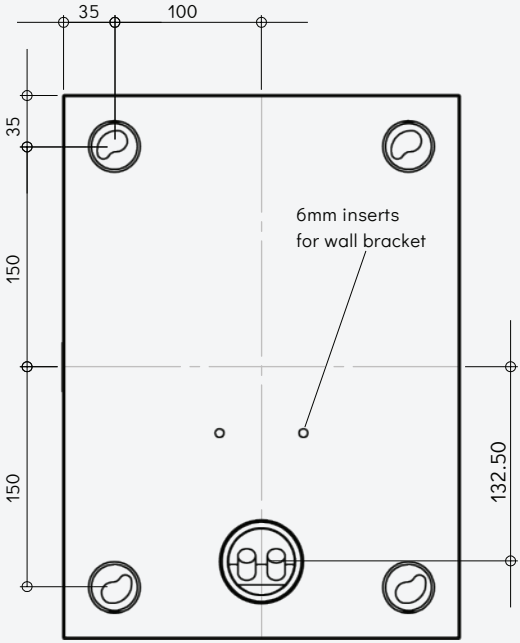

rear view

SCHEMATICS

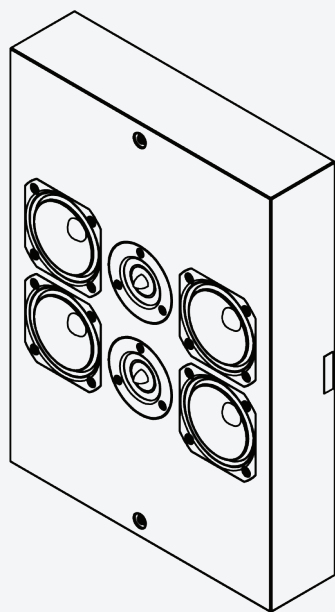

isometric view

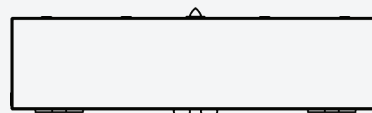

top view

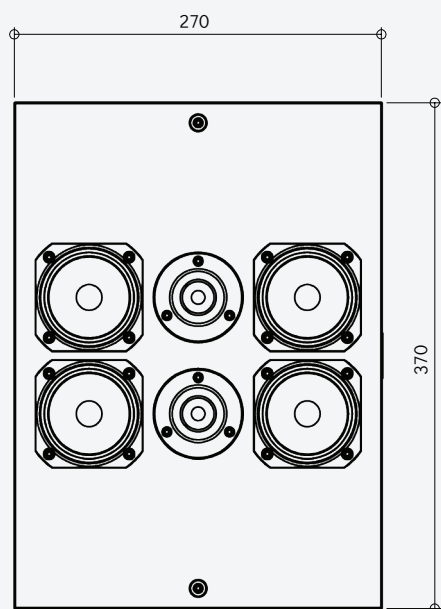

front view

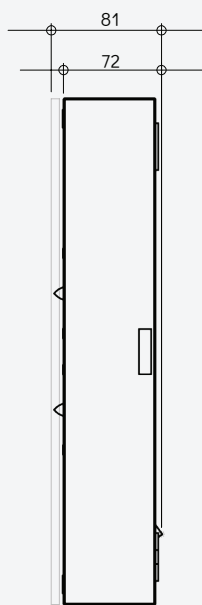

side view

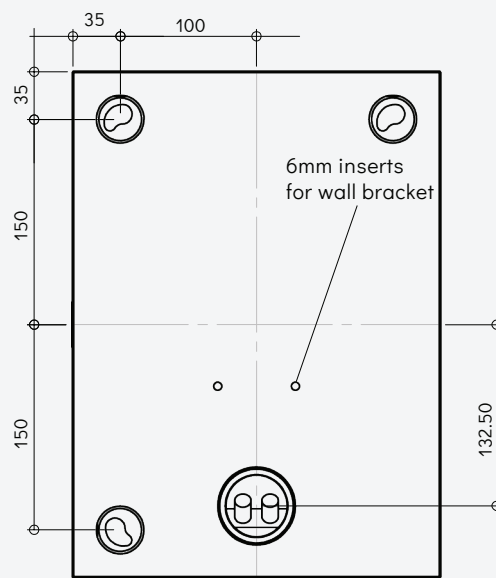

rear view

SCHEMATICS

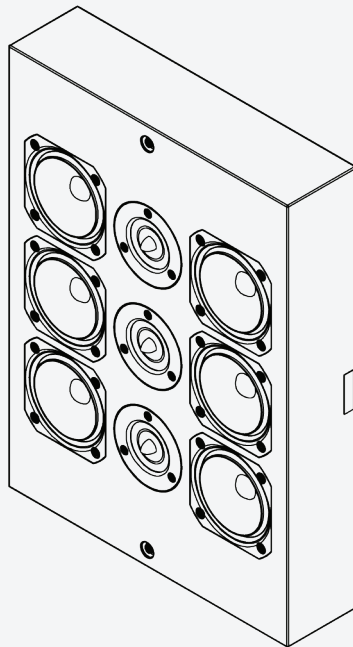

isometric view

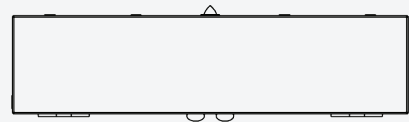

top view

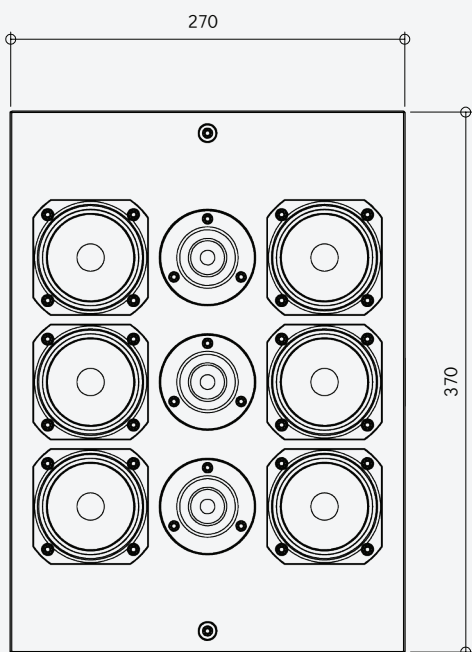

front view

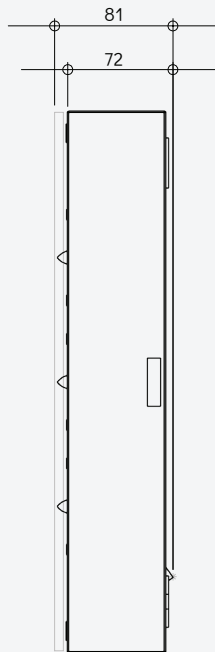

side view

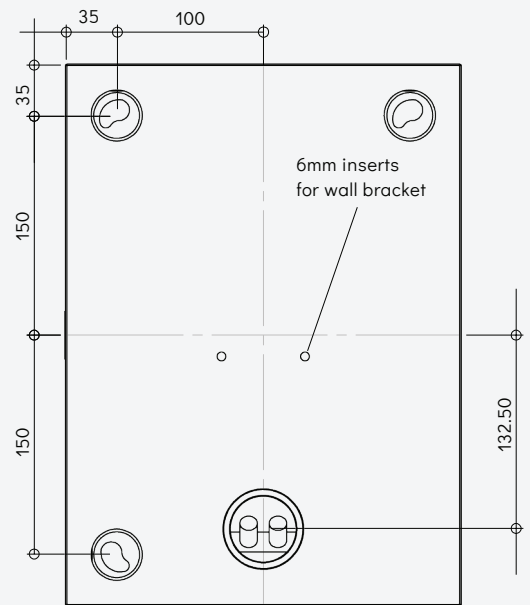

rear view

SCHEMATICS

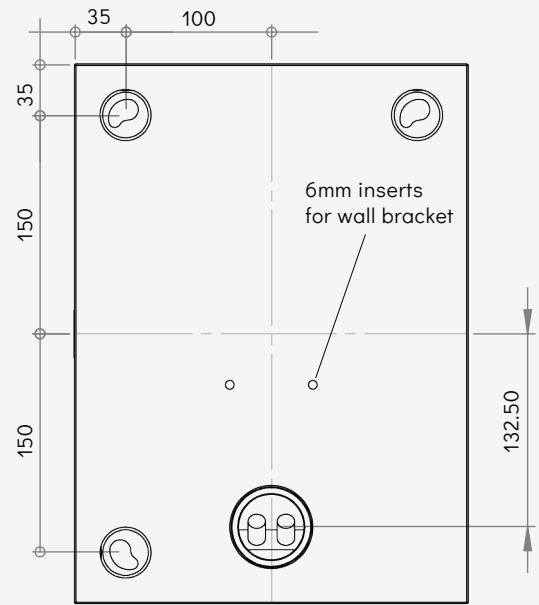
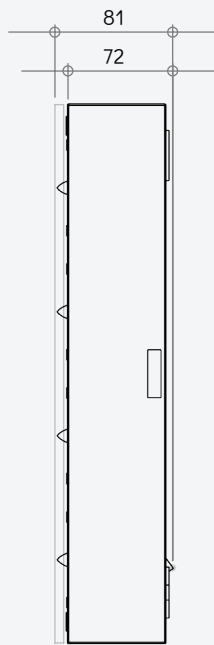
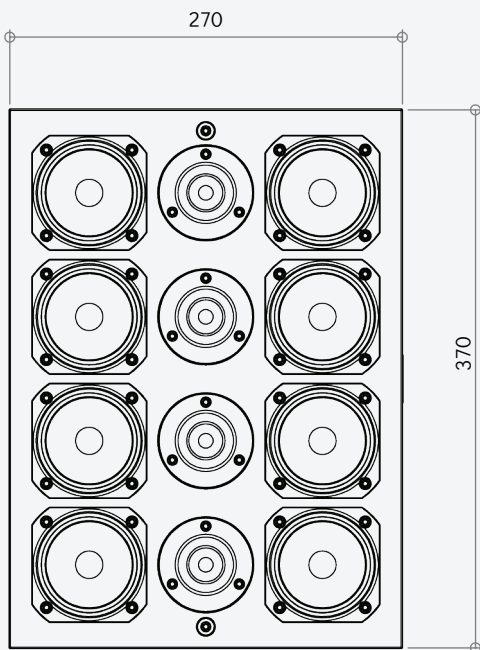
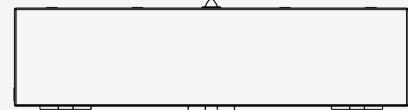
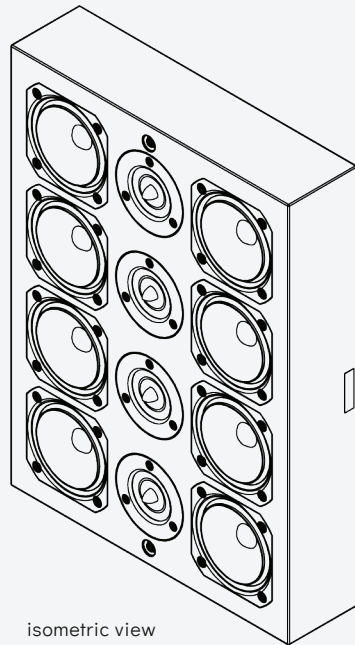

SCHEMATICS

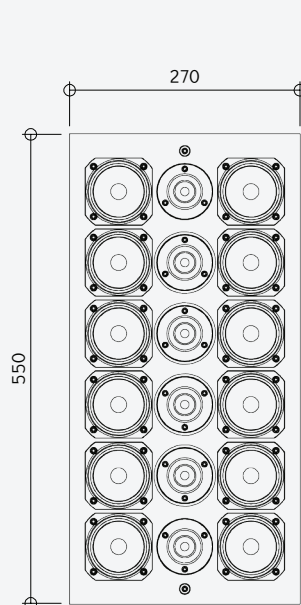

front view

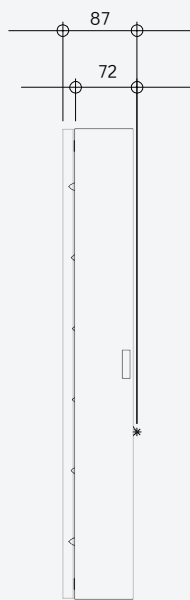

side view

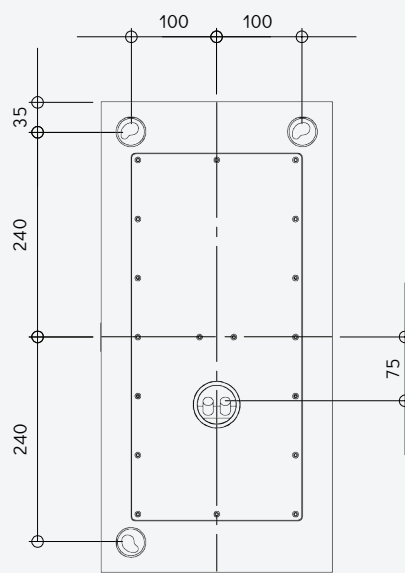

rear view

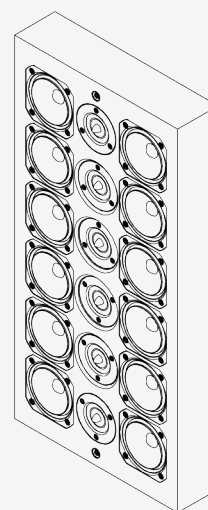

isometric view

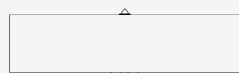

top view

SCHEMATICS

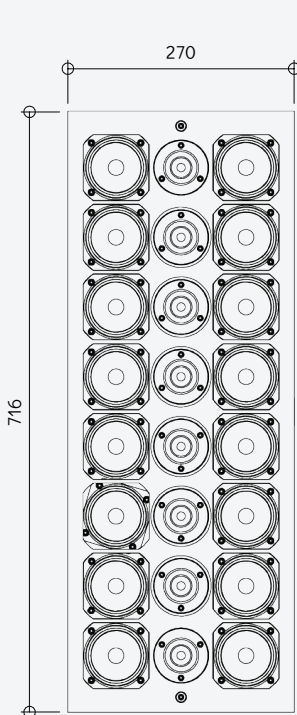

front view

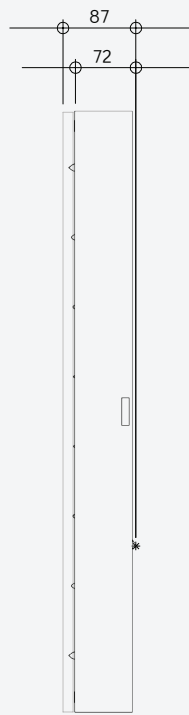

side view

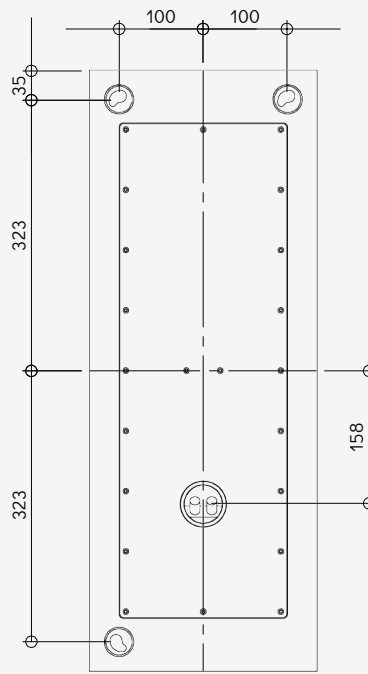

rear view

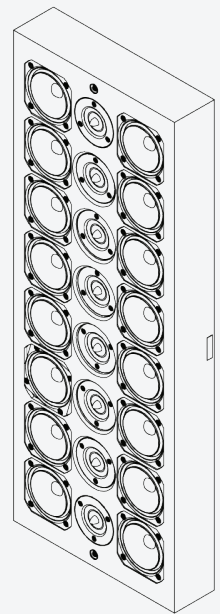

isometric view



top view

SCHEMATICS

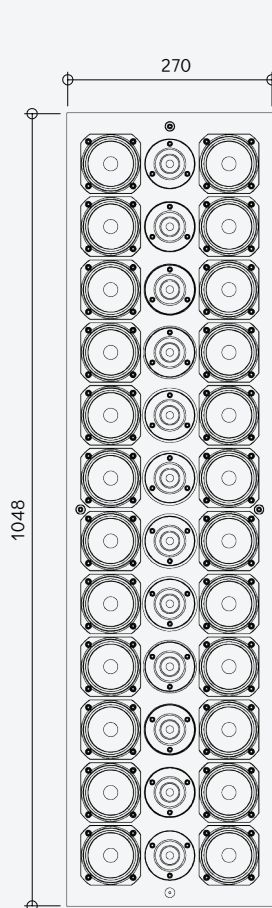

front view

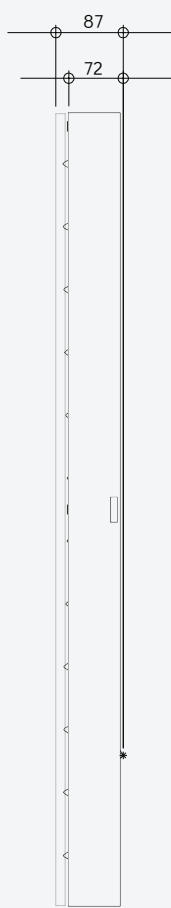

side view

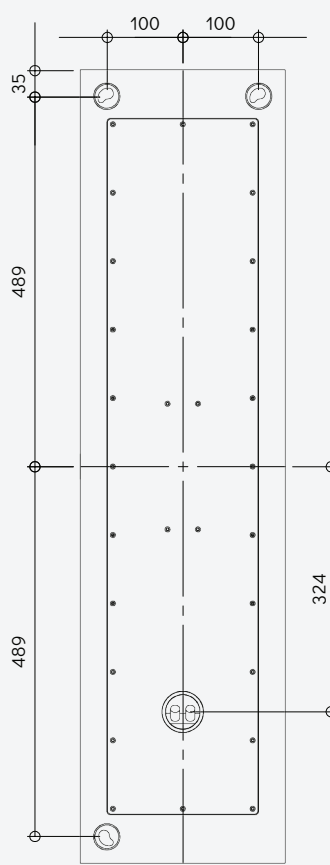

rear view



isometric view



top view

MOUNTING INSTRUCTION



Universal Alu Mount
Mount to wall with suitable wall plugs

isometric rear view side view

SL Evolve 1-1
Mount speaker to bracket, rotating clockwise

inserts wall

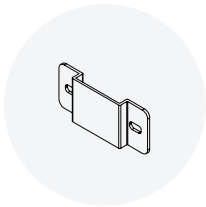

Universal Bracket Mount
Attach bracket mount to speaker rear side

isometric rear view

Artcoustic Universal Bracket
Mount bracket to wall, with suitable screws

SL Evolve 1-1
Fit speaker on bracket mounted on wall

inserts wall

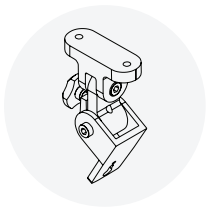

Artcoustic Universal Bracket
Mount bracket to ceiling with suitable screws

isometric rear view

SL Evolve 1-1
Mount bracket to speaker

inserts

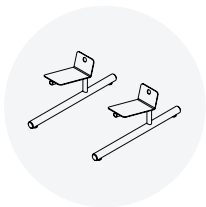

Speaker Stand

SL Evolve 1-1
Mount stands to speaker with supplied screws

MOUNTING INSTRUCTION



Universal Alu Mount
Mount to wall with suitable wall plugs

isometric rear view side view

SL Evolve 2-1
Mount speaker to bracket, rotating clockwise

inserts wall

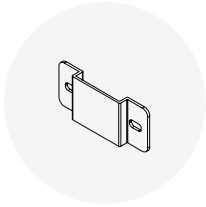

Universal Bracket Mount
Attach bracket mount to speaker rear side

isometric rear view

SL Evolve 2-1
Fit speaker on bracket mounted on wall

inserts wall

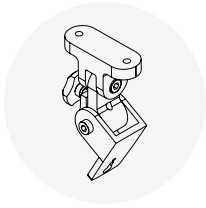

Artcoustic Universal Bracket
Mount bracket to ceiling with suitable screws

SL Evolve 2-1
Mount bracket to speaker

isometric rear view

inserts

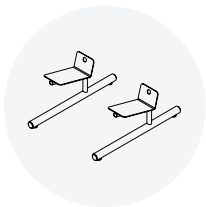

Speaker Stand

SL Evolve 2-1
Mount stands to speaker with supplied screws

MOUNTING INSTRUCTION

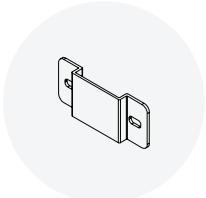

Universal Bracket Mount
Attach bracket mount to
speaker rear side

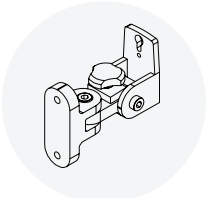

Artcoustic Universal Bracket
Mount Bracket to wall,
with suitable screws

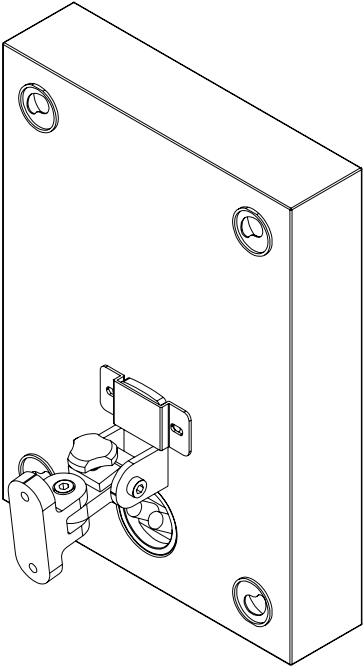
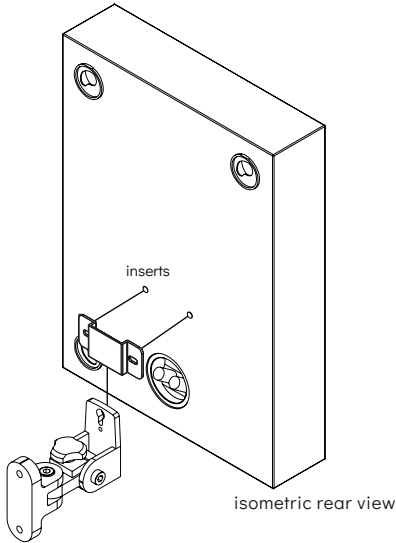

SL Evolve series
Fit speaker on bracket
mounted on wall

POLAR RESPONSE

SL EVOLVE 1-1

horizontal polar response 1m

16000Hz - - - - -
 6500Hz - - - - -
 2500Hz - - - - -
 1000Hz - - - - -

vertical polar response 1m

3D polar response 1m

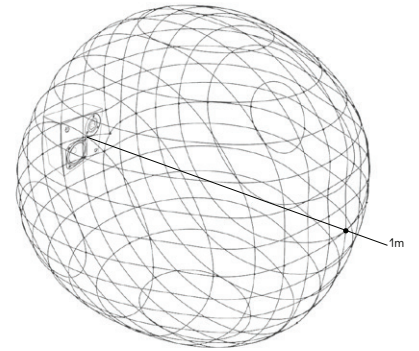
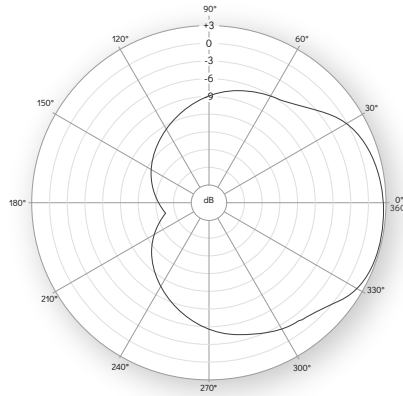
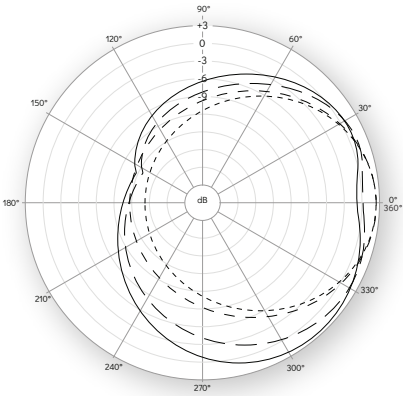

SL EVOLVE 2-1

horizontal polar response 2m

16000Hz - - - - -
 6500Hz - - - - -
 2500Hz - - - - -
 1000Hz - - - - -

vertical polar response 2m

3D polar response 2m

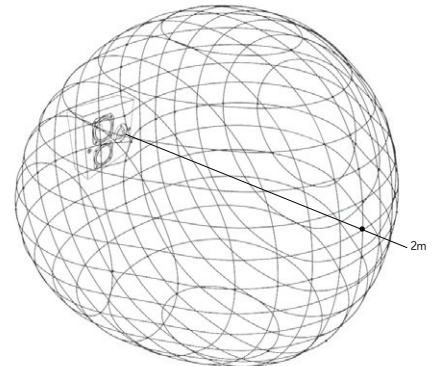
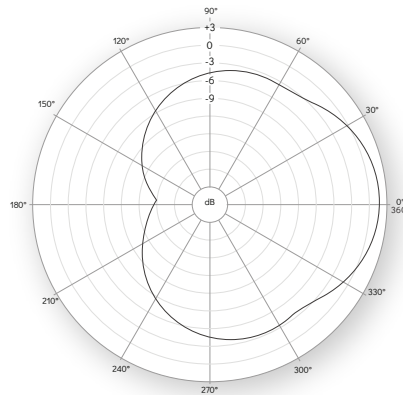
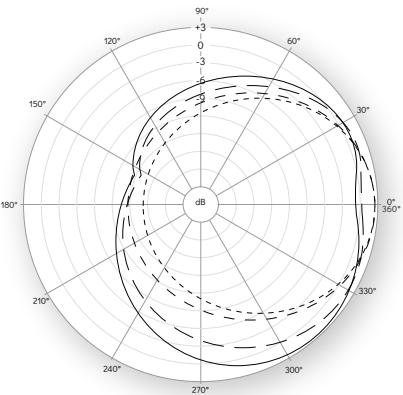

SL EVOLVE 3-1

horizontal polar response 2m

16000Hz - - - - -
 6500Hz - - - - -
 2500Hz - - - - -
 1000Hz - - - - -

vertical polar response 2m

3D polar response 2m

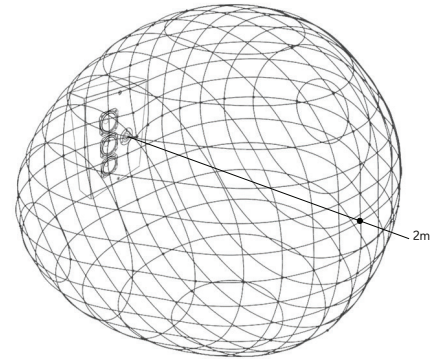
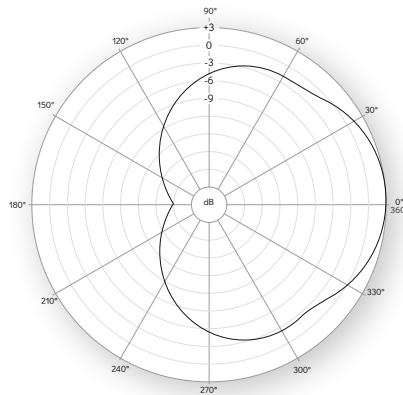
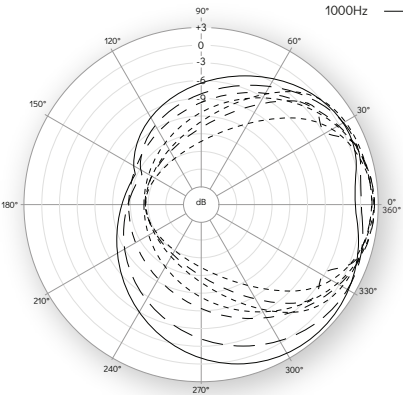

POLAR RESPONSE

SL EVOLVE 4-2

horizontal polar response 2m

16000Hz - - - - -
 6500Hz - - - - -
 2500Hz - - - - -
 1000Hz - - - - -

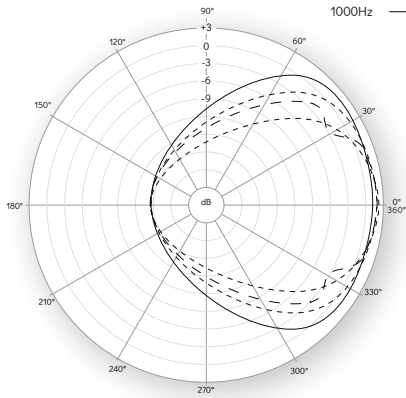

vertical polar response 2m

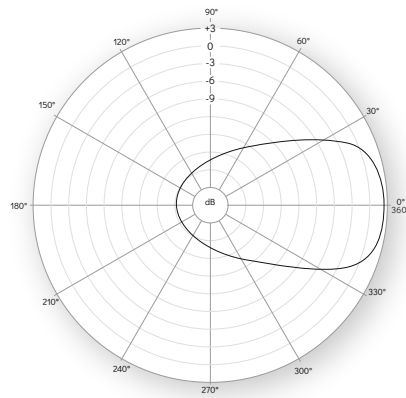

3D polar response 2m

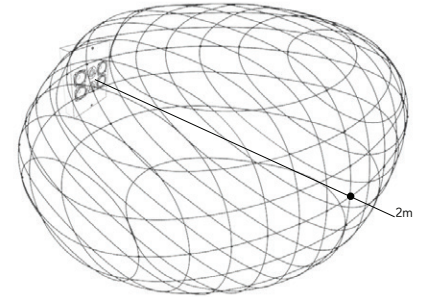

SL EVOLVE 6-3

horizontal polar response 2m

16000Hz - - - - -
 6500Hz - - - - -
 2500Hz - - - - -
 1000Hz - - - - -

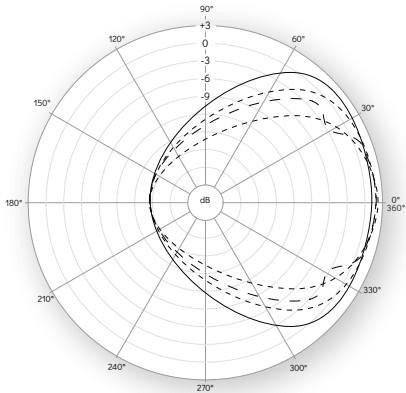

vertical polar response 2m

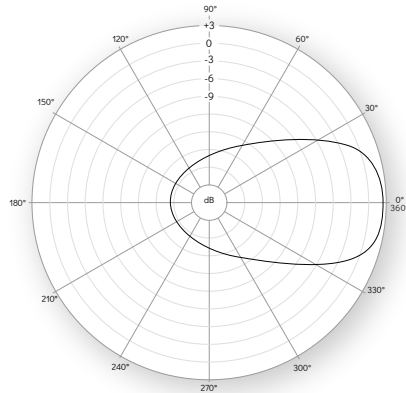

3D polar response 2m

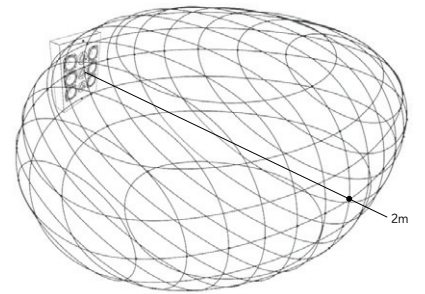

SL EVOLVE 8-4

horizontal polar response 2m

16000Hz - - - - -
 6500Hz - - - - -
 2500Hz - - - - -
 1000Hz - - - - -

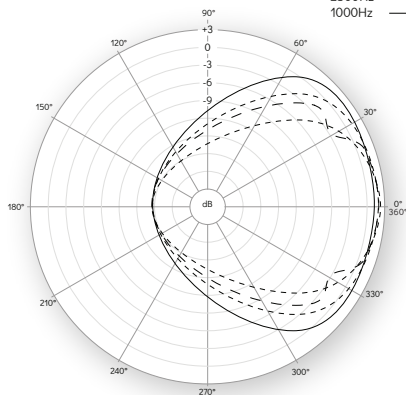

vertical polar response 2m

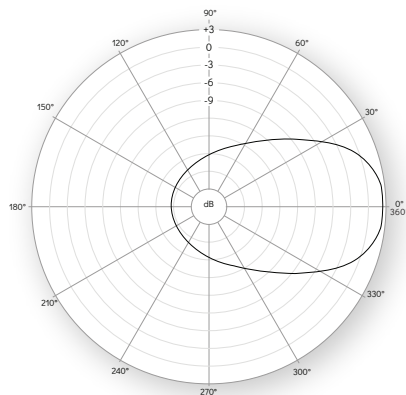

3D polar response 2m

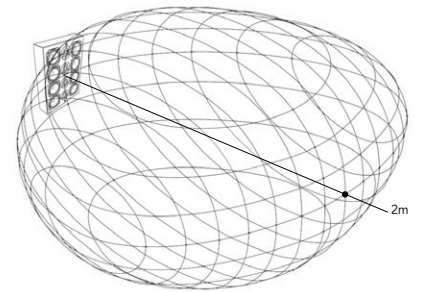

POLAR RESPONSE

SL EVOLVE 12-6

horizontal polar response 2m

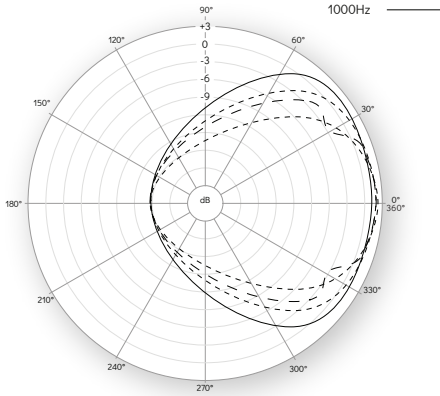

vertical polar response 2m

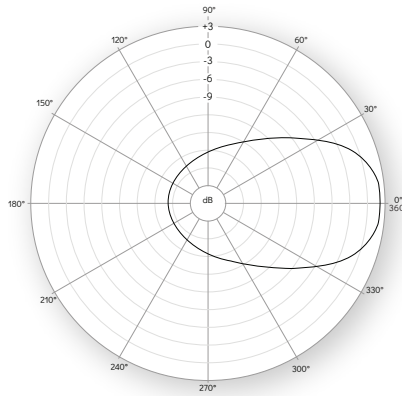

3D polar response 2m

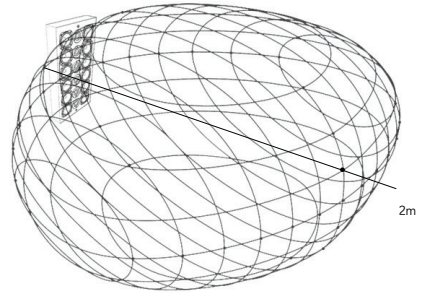

SL EVOLVE 16-8

horizontal polar response 2m

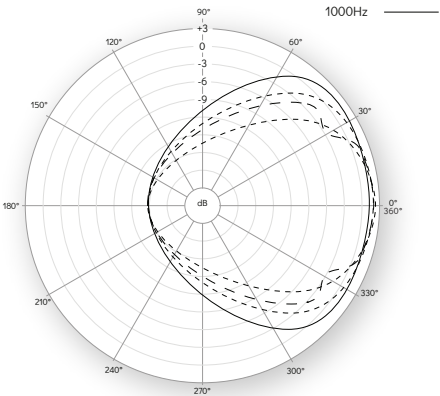

vertical polar response 2m

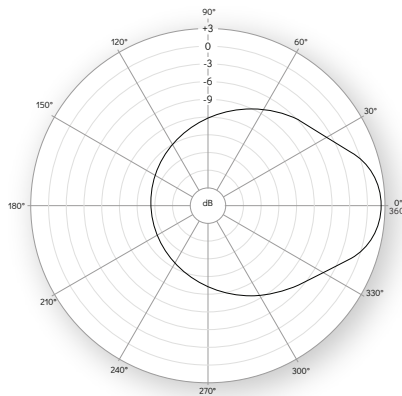

3D polar response 2m

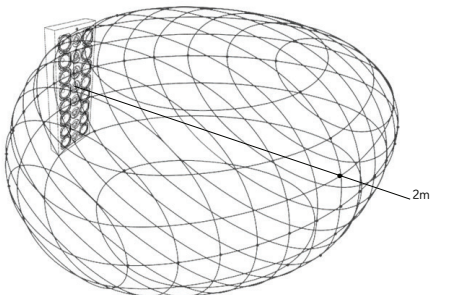

SL EVOLVE 24-12

horizontal polar response 2m

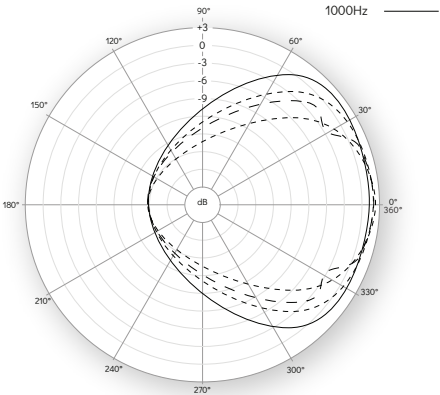

vertical polar response 2m

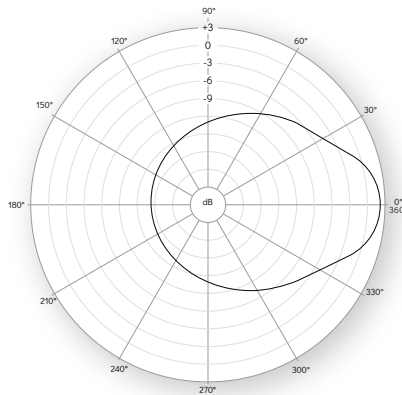

3D polar response 2m

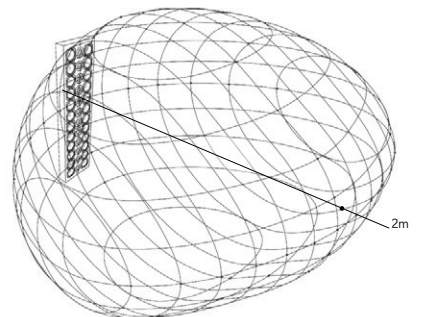

FLUSHED MOUNTED SPEAKERS VS. WALL MOUNTED

On the following page, we take a closer look at the difference between placing a speaker on wall, away from wall and a speaker flushed with a wall, a method used with in-wall speakers and also a method often seen in dedicated cinemas, with screen speakers placed behind a projection screen.

Flush or not to flush, both ways doing this has pros and cons.

Starting out with the flush mounted concept, we clearly illustrate on the following page, placing a speaker flushed in a wall without any use of attenuating material around it, probably is the worse solution of all of them, as this create some very serious wall reflections, resulting in a diffused and overall deteriorated audio quality, so this is something we as a brand rarely recommend, but as we also illustrate, this reflection problem can fairly easy be overcome, with special acoustic treatment, this is however not a very aesthetic solution and would mainly apply to dedicated cinema screen speaker walls.

This solution does come with a couple of problems, by placing a speaker so close to a attenuated wall, at certain frequencies general loss of energy moving forward will occur and this can easily be in the region of 2-3 dB depending on the wall absorption coefficient and type of speaker. Another problem associated with these so called cinema baffles, is the sheer level of complexity making them, making sure they don't rattle or have any other construction technical problems, also a wall like this will add significantly to the cost of the overall cinema room.

It is however important to explain that we have not, on the following page, taking the type of speaker into consideration, without a doubt, Hi-Pass crossed over line array speakers behave better in a cinema baffle, or flat on-wall compared to other more traditional full range point source type of speaker, as these have been designed in a way, producing a controlled vertical and horizontal dispersion pattern and here by effectively deals with unwanted midrange surface reflections and at the same time cutting out the upper low frequency waves, which in most cases seems to be the biggest problem when placing speakers close to walls, these are all technologies which Artcoustic successfully have perfected for now more than 20 years.

The last problem we feel we need to mention, is the fact that a flushed mounted speaker, will lose the ability to be angled in-wards, leaving the left and right screen speaker option in a fixed off axis listening position.

FLUSHED MOUNTED SPEAKERS VS. WALL MOUNTED

On-wall mounted speakers, this is a slightly more complex subject to cover, as on-wall speakers has a greater flexibility in distance to wall, speaker angling etc.

But when we are talking cinema design, on-wall speakers overall performance will as well improve by applying special acoustic treatment in a similar way as with flush mounted speakers, without wall attenuation, on-wall speakers can generate delayed reflections, when coupling with the rear wall, which in some situations can lead to a more diffused audio quality, a problem relatively easily fixed though, the exact same way as with flushed speakers, simply apply acoustic treatment to the given wall, and here by remove the omni directional waves moving around and behind the speakers.

Overall acoustic loss, will very much depend on speaker model and speaker baffle size, but in general, the 2-3 dB loss seen with flush mounted single source full range speakers, is far less common with Artcoustic more narrow dispersion and low frequency cut array speakers, which in short produce more sound directly from the speaker and less sound from surrounding boundaries, with the end result, a cleaner sound, more detailed sound and very important less room depending consistent sound.

At Artcoustic we favour wall mounted speakers, as this gives us a much bigger cinema design freedom, speaker position flexibility and vertical or horizontal angling, also this approach simplify the overall installation, reduce the overall cost and reduce installation time.

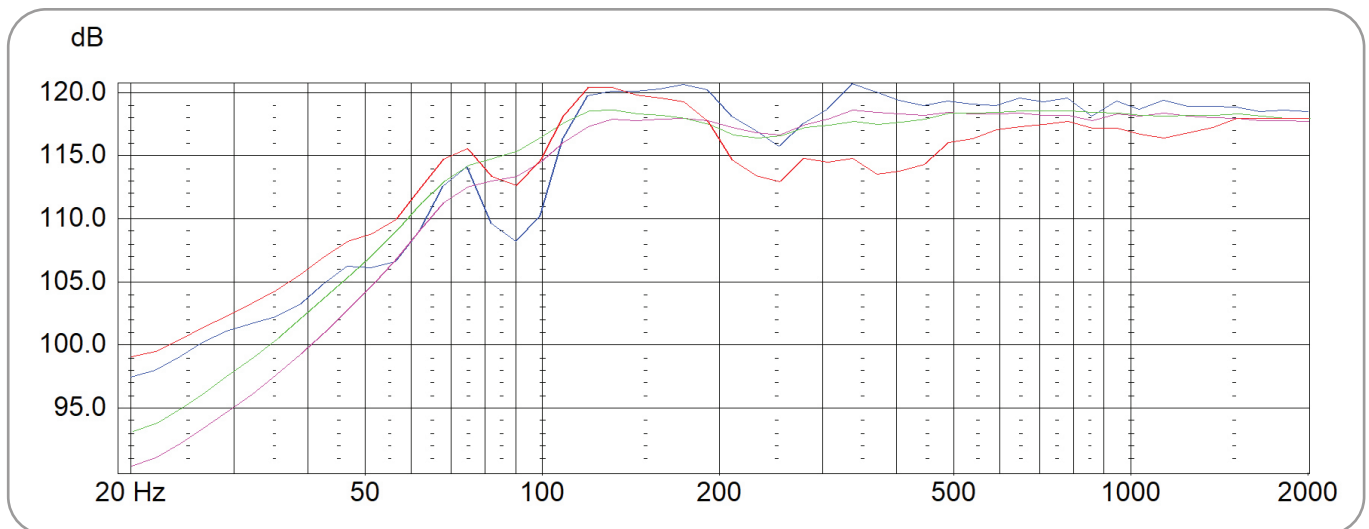

fig. speakers frequency response flushed/wall-mounted

- Speaker 250mm from wall, no attenuation
- Speaker flushed, no attenuation
- Speaker 250mm from wall, with attenuation
- Speaker flushed, with attenuation

Above graphs, indicate the importance of attenuating the screen speaker rear wall, no matter if the speakers are flushed or distanced from wall, with attenuation, +/- 5dB dips and peaks can easily materialize, deteriorating the overall sound quality.

The above graphs has not taken projection screen reflections into consideration, which will only make matters worse.

FLUSHED MOUNTED SPEAKERS VS. WALL MOUNTED

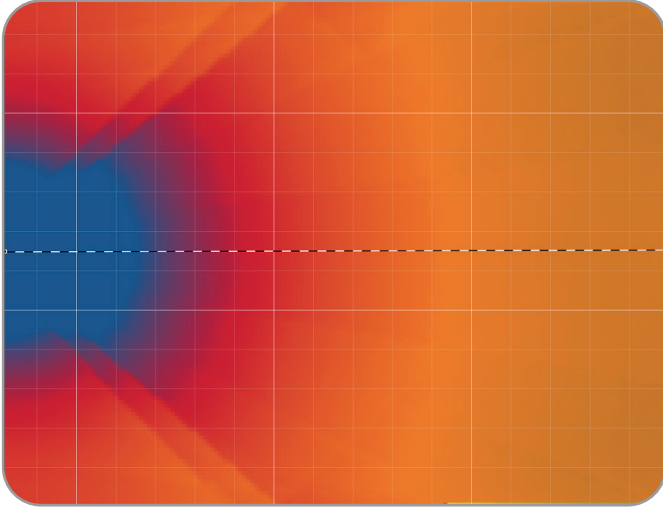

Speaker flushed no attenuation, omni directional dispersion interfere with rear wall, which will result in a rather diffused sound experience

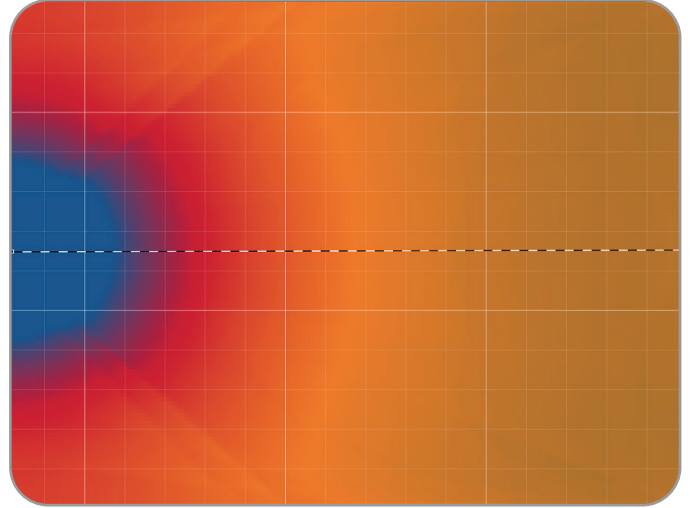

Speaker flushed with attenuation, this will fix some of the rear wall reflections, but the close distance to wall will as well generate a loss of forward protrude energy around 2-3dB

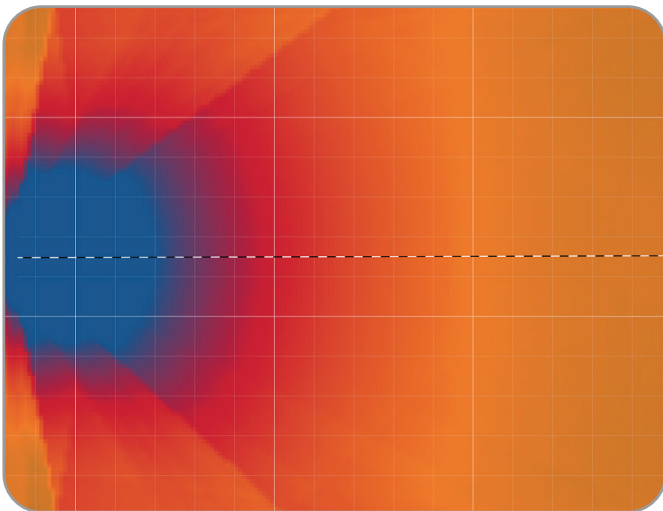

Speaker on wall 250mm from wall, no attenuation, overall less energy coupling with the rear wall, more sound from the actual speaker and speaker baffle, less sound from rear wall

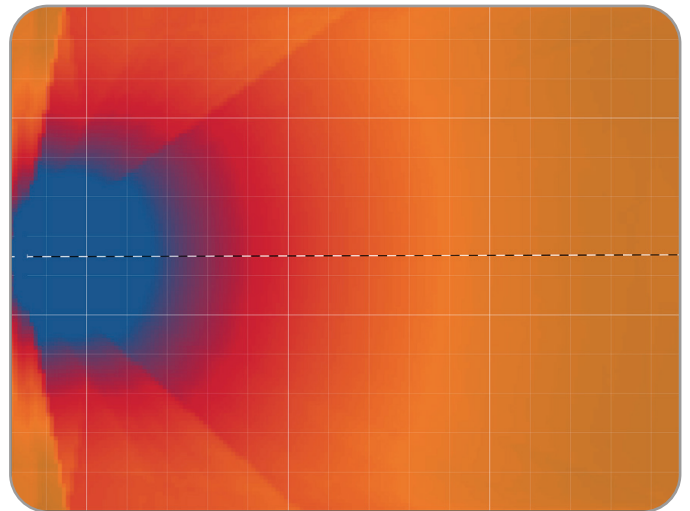

Speaker on wall with attenuation, further decoupling from rear wall energy is being protrude forward, small noticeable heat map energy differences, important to mention, final acoustic outcome, very much depends on speaker type, frequency response and speaker baffle size.

ARTCOUSTIC LINE ARRAY EXPLAINED

As sound is invisible to the human eye, it can for many people come across being a bit abstract and difficult to understand, where on the other hand light is visible to the human eye and therefore easier to explain. However, sound and light actually has many things in common. It is an energy which reflects and absorbs, according to its surroundings, shape boundaries and boundary materials.

With the diagrams shown here, we try to explain the fundamental differences in between the typical omni-directional point source speaker. A more controlled sound source, with guided directivity, illustrating the more professional audio oriented horn loaded design and finally the use of multiple sound sources, placed in a straight or curved vertical line, illustrating the different types of line array designs used by Artcoustic.

illustration with a 30W light bulb

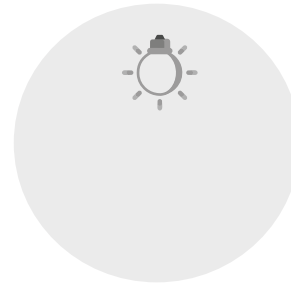

30W wide dispersion typical HI-FI design

illustration with a ceiling lamp

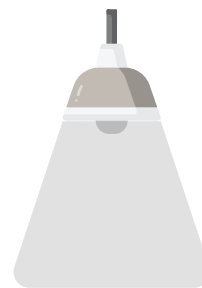

Controlled dispersion typical horn design

illustration of a 120W straight line array

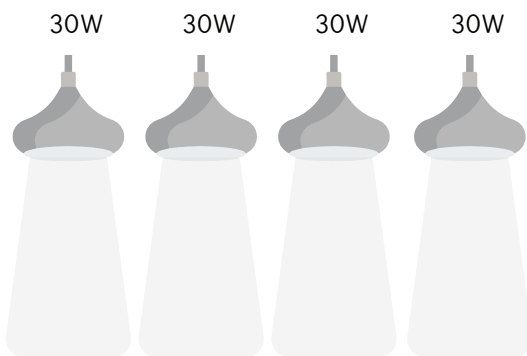

*using Spitfire A6/A4 and smaller Evolve speakers

illustration of a 120W time aligned line array

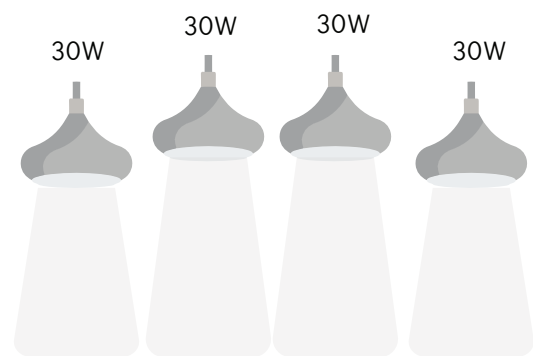

*using larger Evolve speakers

illustration of a 120W angled line array

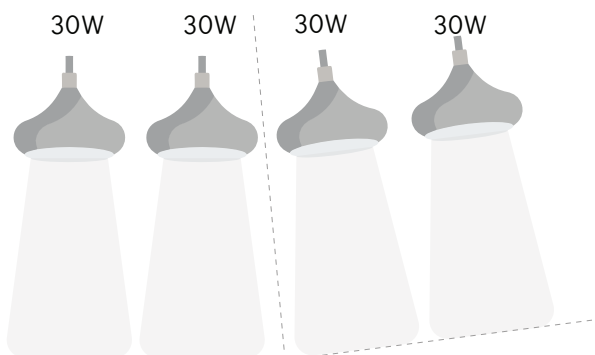

*using Spitfire array speakers

ARTCOUSTIC LINE ARRAY EXPLAINED

In order to give these designs a fair assessment we have used the same input power of 30 Watt and each drive unit has a 85 dB anechoic sensitivity, for the horn loaded design, we have added +10dB sensitivity. This is a rough estimate, as horns come in many shapes and sizes, all behaving very differently.

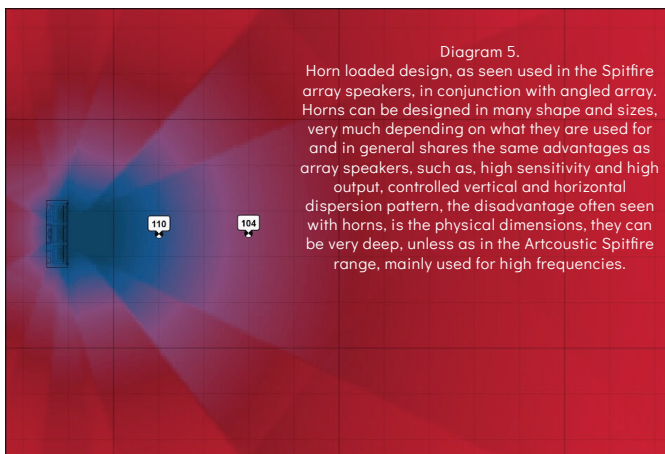
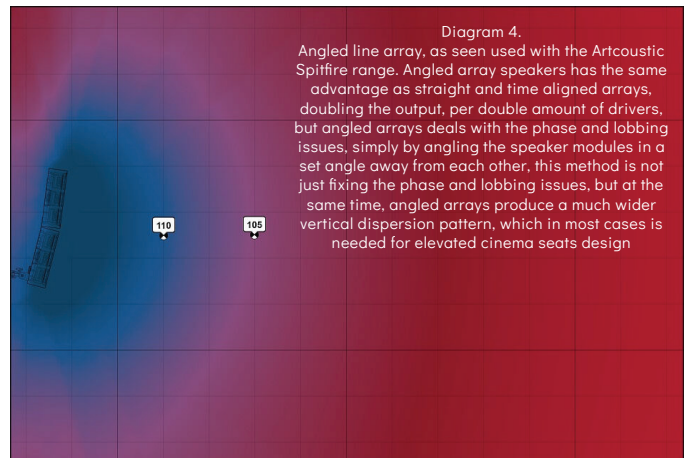
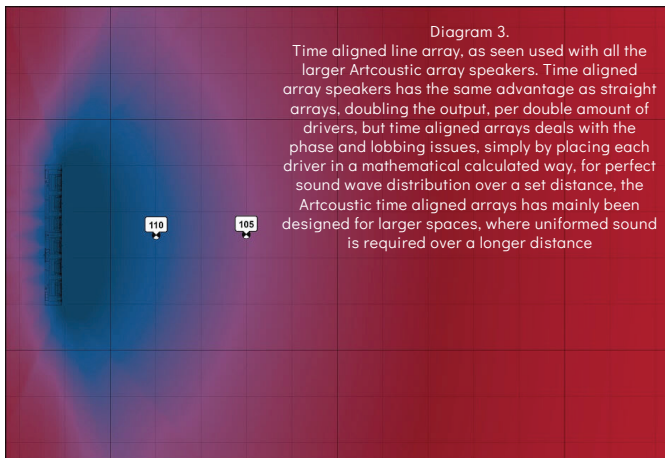
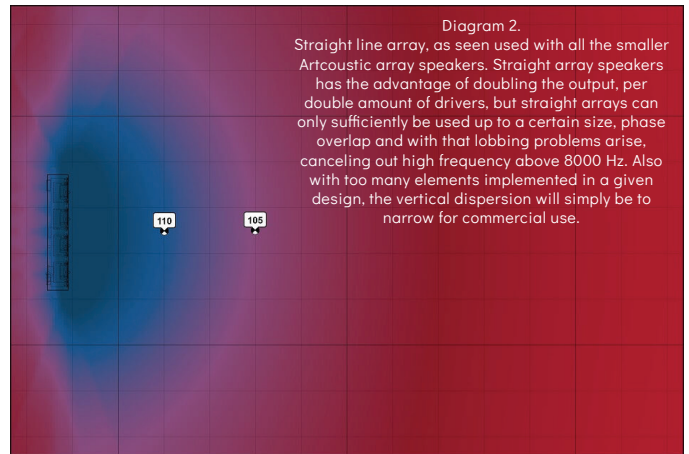
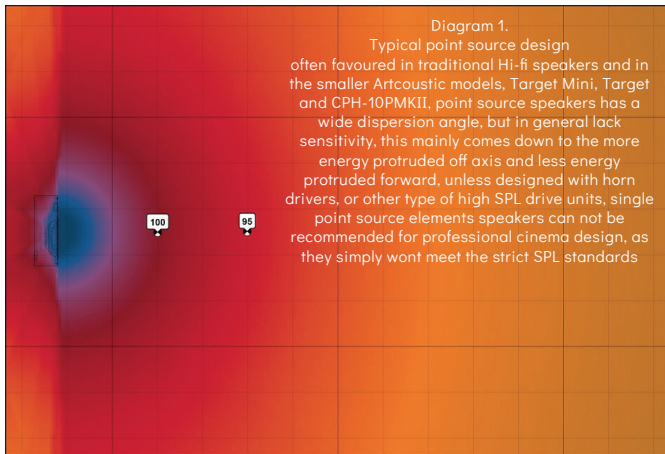

ARTCOUSTIC LINE ARRAY EXPLAINED

ARTCOUSTIC LINE ARRAY ADVANTAGES

As it is with lighting design and methods, all of these audio design solutions has advantages and disadvantages, we have listed out some of the obvious advantages we find important using line array type of designs.

EXTENDED FLAT FREQUENCY RESPONSE UP TO 20KHZ
over a wide horizontal and vertical angle.

DETAILED AND TRANSPARENT SWEET SPOT
with an almost magical ability of making the actual speakers acoustically disappear.

HIGH SENSITIVITY AND EXCEPTIONAL SOUND PRESSURE LEVEL

LOW DISTORTION

BENCH MARK TRANSIENT RESPONSE

GUIDED DIRECTIVITY
with near perfect response curve +/- 3 dB over long distance.

PLUG AND PLAY EASY TO INSTALL APPROACH
eliminating installation mistakes and misunderstandings.

MINIMUM LOSS OF ACOUSTIC ENERGY
over double distance -5 dB.

MINIMUM ROOM ACOUSTIC INTERFERENCE
less room treatment needed.

PREDICTABLE AND CONSISTENT PERFORMANCE

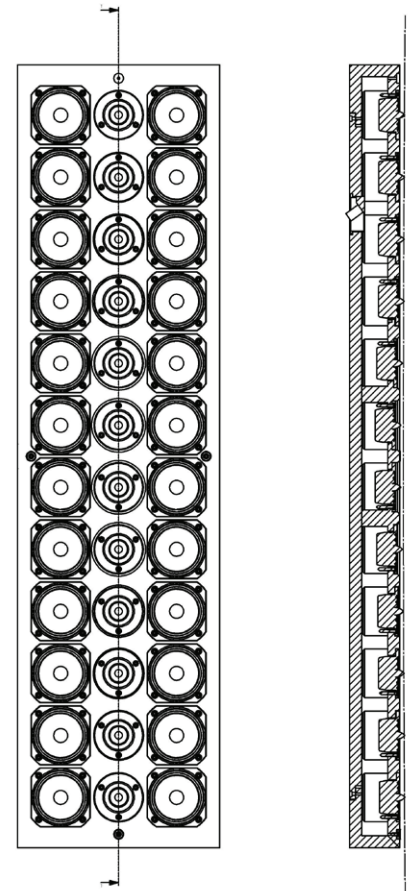

ARTCOUSTIC TIME ALIGNED ARRAY

With the Artcoustic Time Aligned Array, we have managed to solve a number of typical array problems, by placing an even number of high frequency transducers in a precise, mathematically calculated position.

We achieve near perfect frequency response, minimized phase overlap and comb filtering, coupled with exceptional high sound pressure level and reduced acoustic loss over double listening distance.

We have also managed to control the energy output on the vertical axis, reducing floor and ceiling reflections, resulting in a constant and highly predictable performance, so basically with the Artcoustic array speakers, every room will sound the same without the use of extensive acoustic room correction material.

ARRAY SPL VS DISTANCE, HALF SPACE

IMPORTANT!

Estimated SPL over distance are based on on-axis straight line half space parameters and should be used as a general guide line only

SL EVOLVE 3-1 at 90 Watt (Max Power Handling)

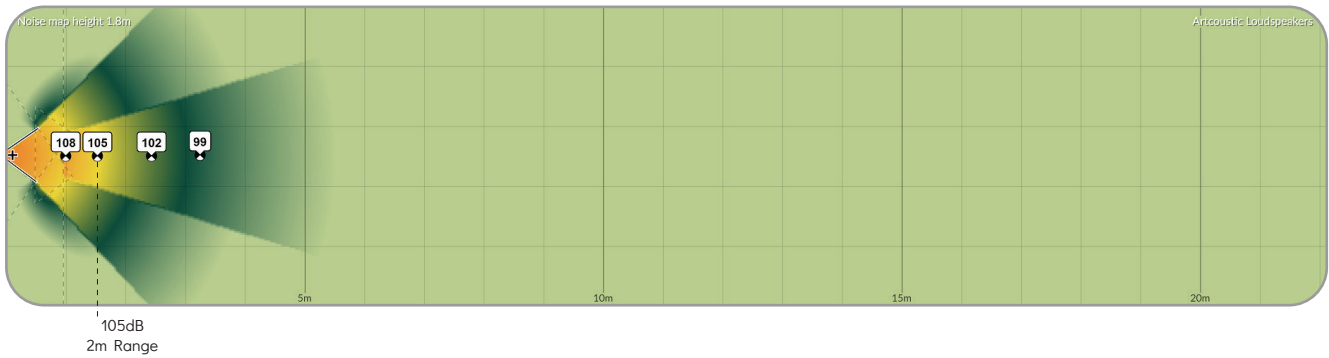

SL EVOLVE 4-2 at 100 Watt (Typical Cinema Receiver output)

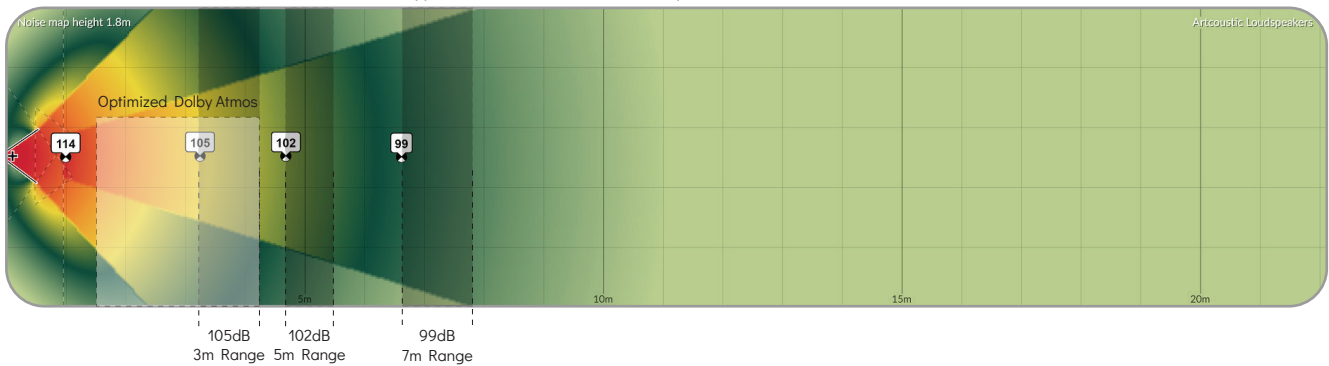

SL EVOLVE 4-2 at 120 Watt (Max Power Handling)

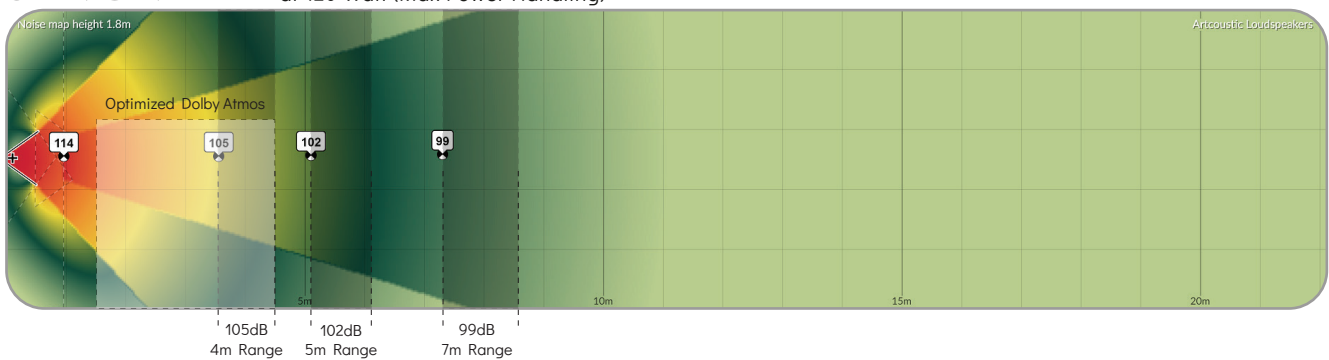

ARRAY SPL VS DISTANCE, HALF SPACE

SL EVOLVE 6-3 at 100 Watt (Typical Cinema Receiver output)

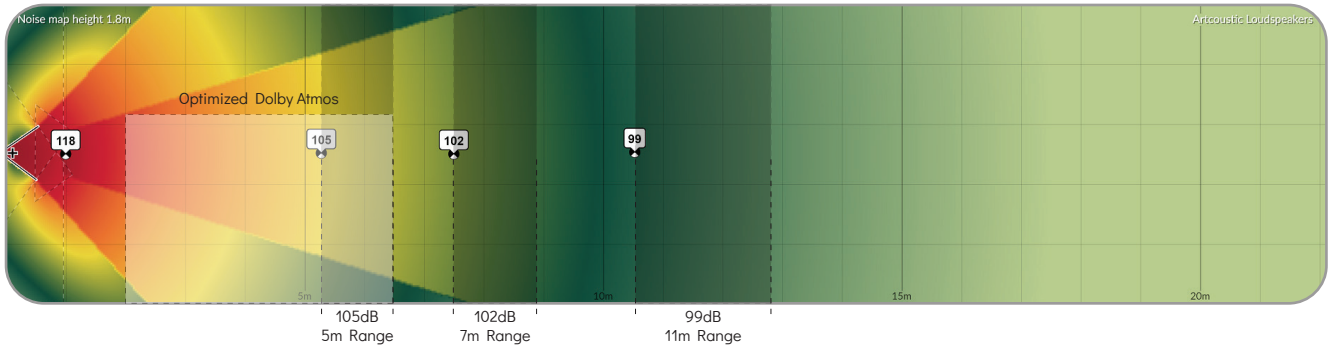

SL EVOLVE 6-3 at 180 Watt (Max Power Handling)

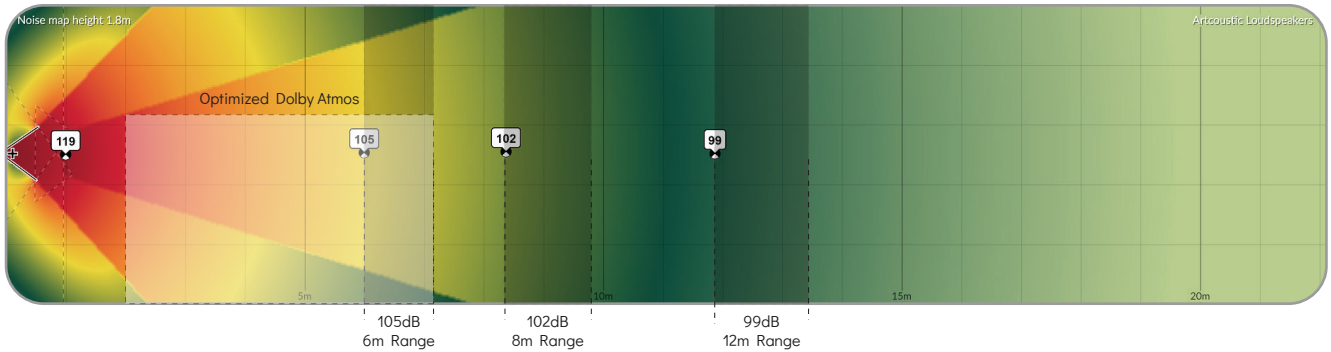

SL EVOLVE 8-4 at 100 Watt (Typical Cinema Receiver output)

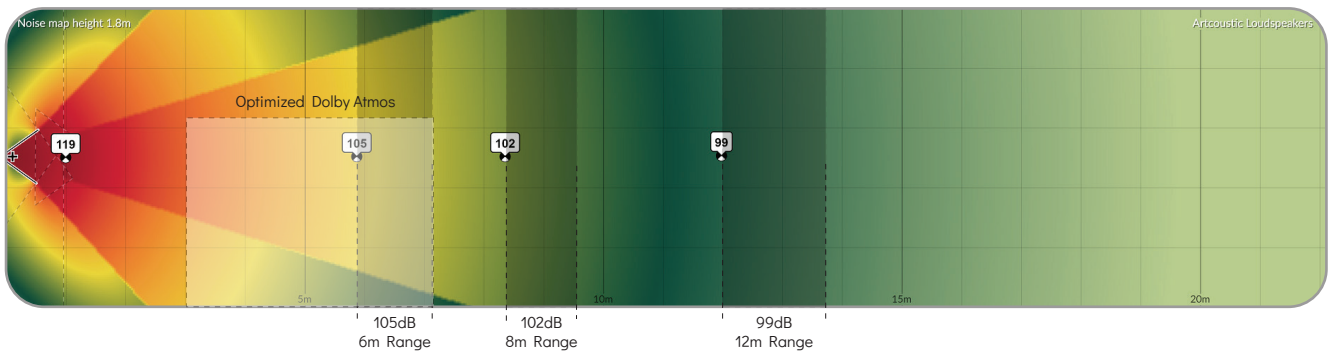

SL EVOLVE 8-4 at 240 Watt (Max Power Handling)

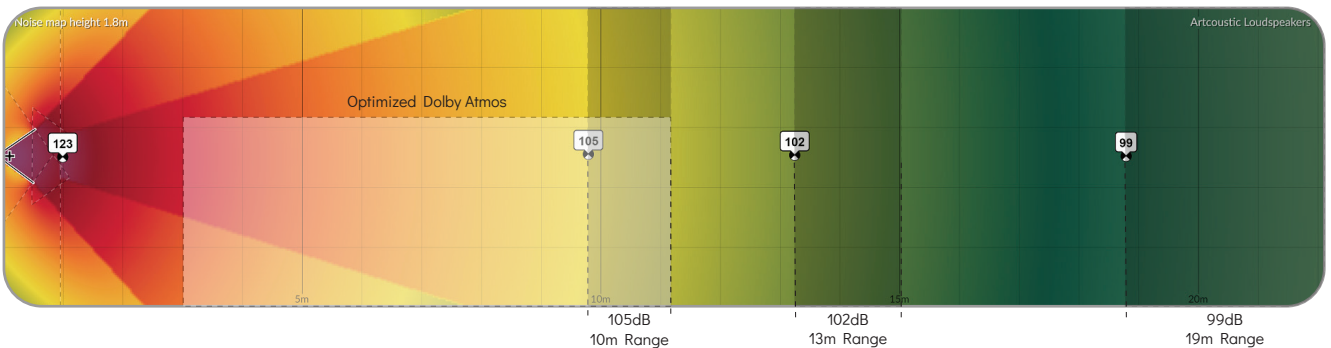

ARRAY SPL VS DISTANCE, HALF SPACE

SL EVOLVE 12-6 at 100 Watt (Typical Cinema Receiver output)

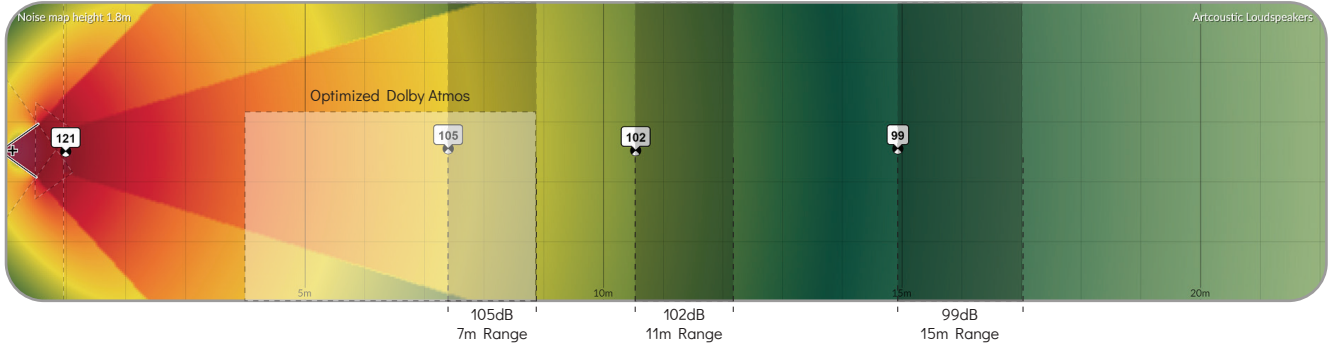

SL EVOLVE 12-6 at 360 Watt (Max Power Handling)

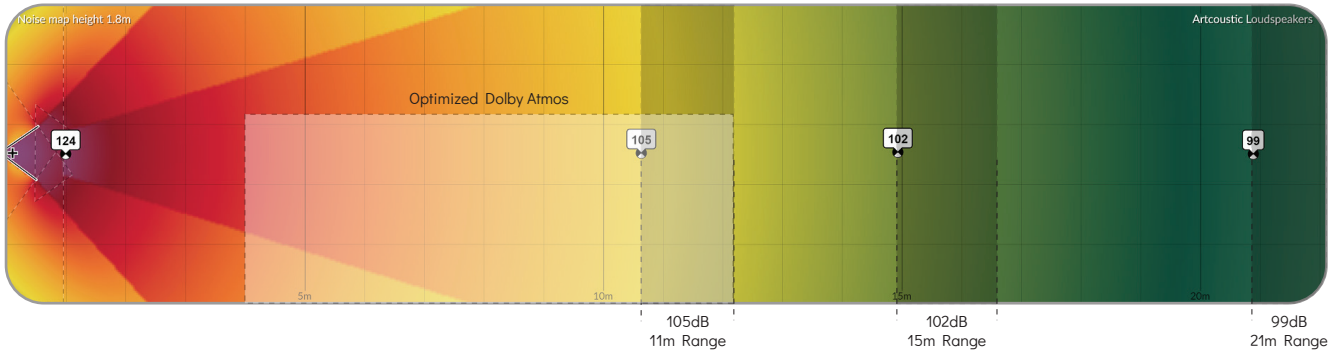

SL EVOLVE 16-8 at 100 Watt (Typical Cinema Receiver output)

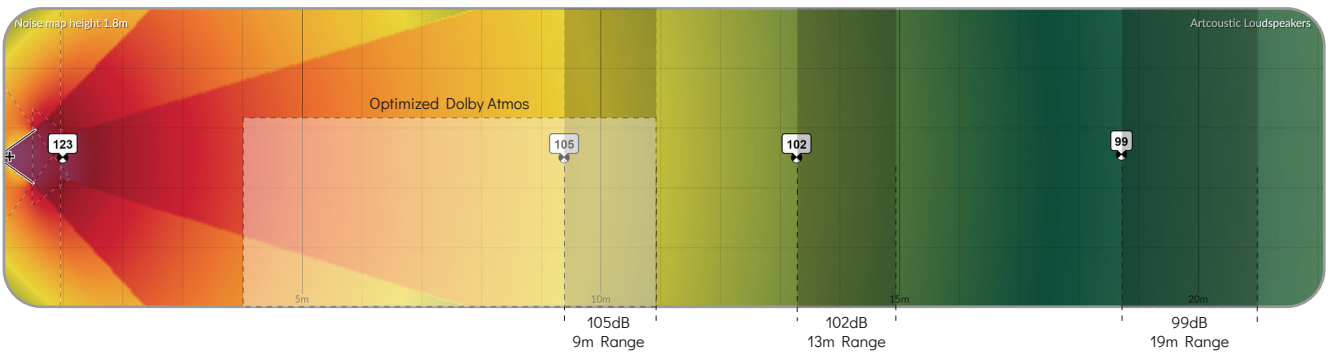

SL EVOLVE 16-8 at 480 Watt (Max Power Handling)

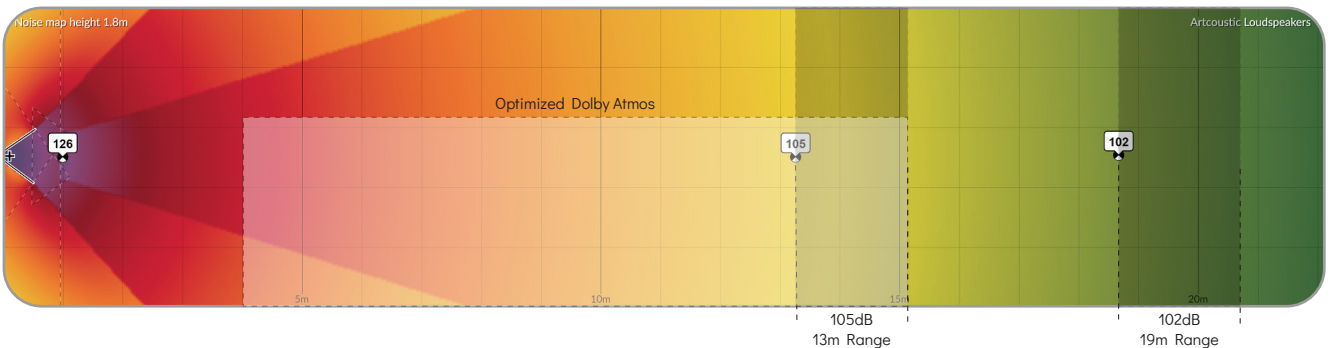

ARRAY SPL VS DISTANCE, HALF SPACE

SL EVOLVE 24-12 at 100 Watt (Typical Cinema Receiver output)

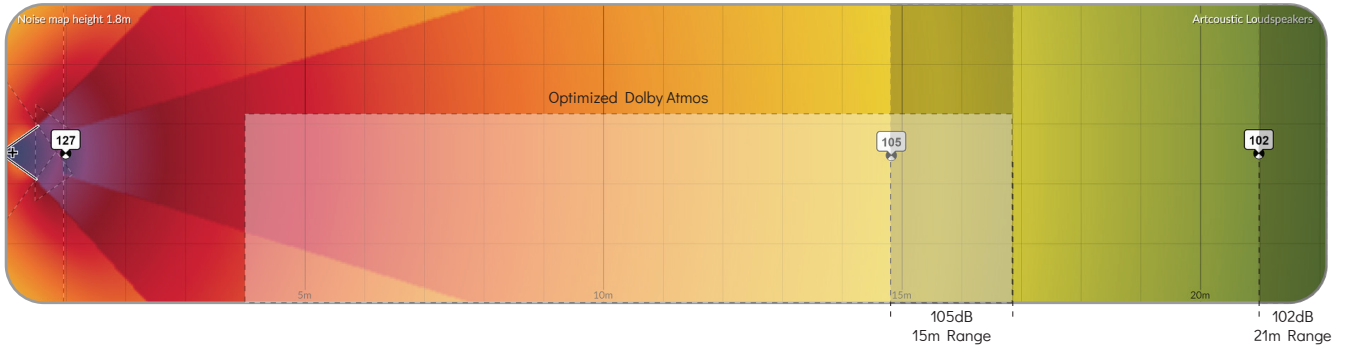

SL EVOLVE 24-12 at 720 Watt (Max Power Handling)

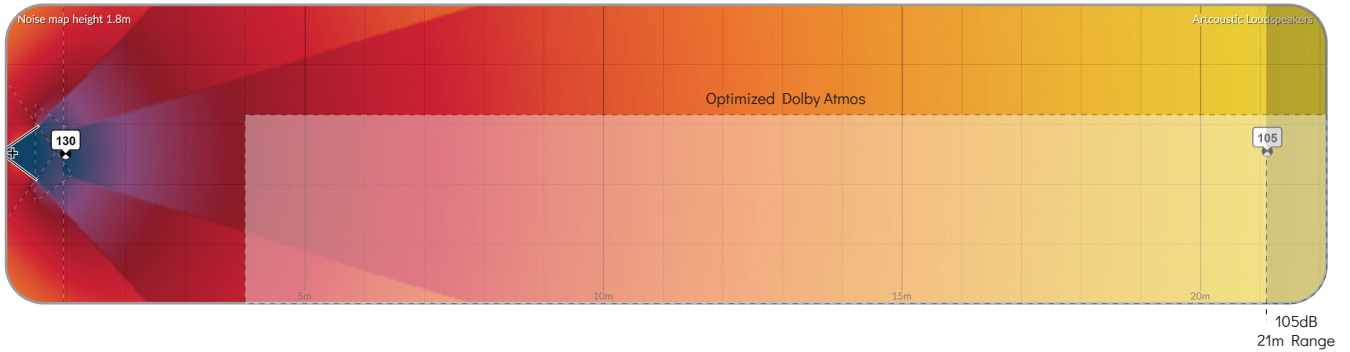

SAFETY INSTRUCTIONS

SAFETY



Do not use this product near water



Clean rear panel with dry cloth only



Do not block any ventilation opening



Do not install near any heat sources



If wall-mounted, ensure the use of matching screws and rawl plugs

WARNING

This product complies with Part 15 of the FCC Rules. Its operation is subject to the following two conditions:

- This product may not cause harmful interference.
- This product must accept any interference received, including interference that may cause undesired operation.

Changes or modifications not expressly approved by the party responsible for compliance could void the user's authority to operate the equipment.

To reduce the risk of fire and electric shock do not expose this product to rain or moisture.



Do not place product filled with liquids such as vases on the product.



Do not open product. There are no user-serviceable parts inside.



Always use the power supply shipped with this product. Using a power supply with wrong voltage or polarity, can damage the electronics.



WARRANTY

IS APPLICABLE



Is valid only for products purchased from an authorised Artcoustic retailer or dealer.



Is valid from the date of purchase for a period of 3-years for passive loudspeakers, and 2-years for powered loudspeakers and electronics.



Is limited to the repair of the equipment (which could be a repair or replacement at our discretion, neither of which affects your original warranty).



Neither transportation, nor any other costs, nor any risk for removal, transportation and installation of products is covered by this warranty.

IS NOT APPLICABLE

Will not be applicable in cases other than defects in materials and/or workmanship at the time of purchase and will not be applicable:

- For deterioration of component parts, the nature of which is to become worn or depleted with use, such as batteries.
- For damages caused by incorrect installation, connection or packing.
- For damages caused by accidents, lightning, water, fire heat, war, public disturbances or any other cause beyond the reasonable control of Artcoustic and its appointed distributors.
- For damages caused by any use other than correct use described in the user manual, negligence, modifications, or use of parts that are not made or authorized by Artcoustic.

If it is found necessary to return the product for repair, you will be given a form to fill out and return. You should not return the product without previous acceptance. To validate your warranty, you will need to produce the original sales invoice or other proof of ownership and date of purchase.